

AI-16458

4.

Common Levee Change Order 1,2,3

DRAINAGE DISTRICT

Date: 07/14/2009

Submitted By: Minerva Luna, DRAINAGE DISTRICT

Department: DRAINAGE DISTRICT

Information

CAPTION

Request approval of Change Order No. 1, No. 2 and No. 3 on the Contract with Ballenger Construction Company for the Construction of the Common Levee/Anzalduas Dike Improvements, Hidalgo Loop Levee to Anzalduas Dam Project.

BACKGROUND

Fiscal Impact

Attachments

Link: [Common Levee CO#1](#)

Link: [Common Levee CO#2](#)

Link: [Common Levee CO#3](#)

Form Routing/Status

Route Seq	Inbox	Approved By	Date	Status
1	Budget & Management	Erika Zamora	07/10/2009 01:20 PM	APRV
2	Sylvia Solis	Sylvia Solis	07/10/2009 04:04 PM	APRV
3	Final Approval		07/10/2009 05:06 PM	NEW

Form Started By: Minerva Luna
Started On: 07/10/2009 10:10 AM
Final Approval Date: 07/10/2009

HIDALGO County Drainage District No. 1
LEVEE IMPROVEMENTS PROJECT
COMMON LEVEE (5.35 MILES)

CHANGE ORDER NO. 1

Date: April 16, 2009

Contractor: Ballenger Construction Company
24200 North FM 509
Harlingen, Texas 78550

Owner: Hidalgo County Drainage District No. 1
902 N. Doolittle Road
Edinburg, Texas 78541

Reference: LEVEE IMPROVEMENTS PROJECT
COMMON LEVEE (5.35 MILES)

Contract No. 08-007-05-27
Dannenbaum No. 4287-04

Description:
Adjusted Embankment quantity.

Contract Amount:

Original Contract Price:	\$	7,593,164.28
Previous Change Order(s):	\$	-
Contract price prior to this change order:	\$	7,593,164.28
Net increase (decrease) from this change order:	\$	(72,067.98)
Contract price with all change orders to date (including this change order):	\$	<u>7,521,096.30</u>

Contract Time:

Authorized contract time change:	
This Change Order	0 days
Previous Total	0 days
Total to Date	<u>0 days</u>

APPROVALS:

ENGINEER:
Dannenbaum Engineering Company - McAllen, LLC



Richard D. Seitz, P.E. Date 7/16/09
Resident Project Representative

OWNER:
Hidalgo Co. Drainage Dist. No. 1

JD Salinas Date
Chairman of the Board

ACCEPTED:

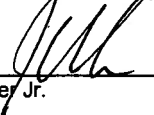
CONTRACTOR:
Ballenger Construction Company

Joe C. Ballenger Jr. Date 7/2/09
President

HIDALGO COUNTY
JUL 07 2009
DRAINAGE DISTRICT #1



HIDALGO COUNTY DRAINAGE DISTRICT NO. 1
LEVEE IMPROVEMENTS PROJECT

CHANGE ORDER NO. 1

ATTACHMENT B

Date: July 7, 2009

Contractor: BALLENGER CONSTRUCTION
CO.
24200 North FM 509
Harlingen, Texas 78550

Owner: Hidalgo County Drainage District No. 1
902 N. Doolittle Road
Edinburg, Texas 78541

Reference: MISSION LEVEE IMPROVEMENTS
PROJECT
COMMON LEVEE / ANZALDUAS
DIKE IMPROVEMENT PROJECT
(5.35 MILES)

Contract No. 08-007-05-21

Dannenbaum No. 4287-04

ENGINEER'S EXPLANATION

DESCRIPTION OF CHANGE

Adjusted Embankment quantity.

JUSTIFICATION FOR CHANGE

A credit for Embankment material taken from the North Interior Levee to the Common Levee will be given back to Hidalgo County Drainage District No. 1.

ENGINEER'S JUSTIFICATION OF COST

Straight unit cost change order, no backup calculations required.

HIDALGO COUNTY

JUL 07 2009

DRAINAGE DISTRICT #1

HIDALGO County Drainage District No. 1
LEVEE IMPROVEMENTS PROJECT
COMMON LEVEE (5.35 MILES)

CHANGE ORDER NO. 2

Date: July 1, 2009

Contractor: Ballenger Construction Company
24200 North FM 509
Harlingen, Texas 78550

Owner: Hidalgo County Drainage District No. 1
902 N. Doolittle Road
Edinburg, Texas 78541

Reference: LEVEE IMPROVEMENTS PROJECT
COMMON LEVEE (5.35 MILES)

Contract No. 08-007-05-27
Dannenbaum No. 4287-04

Description:

Removed Gatewell Structures 307 and 313 and added new bid items for pipe, headwall and manhole.

Contract Amount:

Original Contract Price:	\$	7,593,164.28
Previous Change Order(s):	\$	(72,067.98)
Contract price prior to this change order:	\$	7,521,096.30
Net increase (decrease) from this change order:	\$	(92,407.80)
Contract price with all change orders to date (including this change order):	\$	<u>7,428,688.50</u>

Contract Time:

Authorized contract time change:	
This Change Order	0 days
Previous Total	<u>0</u> days
Total to Date	0 days

APPROVALS:

ENGINEER:
Dannenbaum Engineering Company - McAllen, LLC

Richard D. Seitz, P.E. Date
Resident Project Representative

OWNER:
Hidalgo Co. Drainage Dist. No. 1

JD Salinas Date
Chairman of the Board

ACCEPTED:

CONTRACTOR:
Ballenger Construction Company

Joe C. Ballenger Jr. Date
President

DRAINAGE DISTRICT #1

JUL 07 2009

HIDALGO COUNTY

Contract No.: 08-007-05-27
Dannenbaum: 4287-04
Change Order No. 2: Change Order No. 2
Description: Work around Gatewell Structure 313

Labor

Description	Labor	Days	Hours Per Day	Total Hours	Rate Per Hour	Total Cost
Foreman	1.00	5.00	10.00	50.00	\$ 21.45	\$ 1,072.50
Pipe Layer	1.00	5.00	10.00	50.00	\$ 8.44	\$ 422.00
Laborer	2.00	5.00	10.00	100.00	\$ 9.05	\$ 905.00
Loader Operator	1.00	5.00	10.00	50.00	\$ 8.61	\$ 430.50
Excavator Operator	1.00	3.00	10.00	30.00	\$ 10.83	\$ 324.90
Roller Operator	1.00	5.00	10.00	50.00	\$ 7.17	\$ 358.50
Subtotal						\$ 3,513.40
Labor burden	55%					\$ 1,932.37
Labor Comp.	25%					\$ 878.35
						\$ 6,324.12

Equipment

Description	Quantity	Days	Hours Per Day	Total Hours	Rate Per Hour	Total Cost
Excavator	1.00	3.00	10.00	30.00	\$ 120.00	\$ 3,600.00
Crew Truck	1.00	5.00	10.00	50.00	\$ 25.00	\$ 1,250.00
Roller	1.00	5.00	10.00	50.00	\$ 35.13	\$ 1,756.50
Pipe Laser	1.00	5.00	10.00	50.00	\$ 6.95	\$ 347.50
Front End Loader	1.00	5.00	10.00	50.00	\$ 34.00	\$ 1,700.00
Subtotal						\$ 8,654.00
Equip comp	15%					\$ 1,298.10
						\$ 9,952.10

Materials

Description	Qty	Unit	Unit Cost	Total
24" RCP Class III	784.00	LF	\$ 16.22	\$ 12,716.48
6' Concrete Manhole	1.00	EA	\$ 3,757.99	\$ 3,757.99
24" Concrete Headwall	2.00	EA	\$ 450.00	\$ 900.00
Subtotal				\$ 17,374.47
Material comp	25%			\$ 4,343.62
				\$ 21,718.09

Total

Total Labor and Material Cost \$ 37,994.31
Item total **\$ 37,994.31**

Cost Breakdown			
24" RCP Class III	85%	\$	32,295.16
6' Concrete Manhole	12%	\$	4,559.32
24" Concrete	3%	\$	1,139.83

HIDALGO COUNTY

JUL 07 2009

DRAINAGE DISTRICT #1

HIDALGO COUNTY DRAINAGE DISTRICT NO. 1
LEVEE IMPROVEMENTS PROJECT

CHANGE ORDER NO. 2

ATTACHMENT B

Date: July 7, 2009

Contractor: BALLENGER CONSTRUCTION
CO.
24200 North FM 509
Harlingen, Texas 78550

Owner: Hidalgo County Drainage District No. 1
902 N. Doolittle Road
Edinburg, Texas 78541

Reference: MISSION LEVEE IMPROVEMENTS
PROJECT
COMMON LEVEE / ANZALDUAS
DIKE IMPROVEMENT PROJECT
(5.35 MILES)

Contract No. 08-007-05-21

Dannenbaum No. 4287-04

ENGINEER'S EXPLANATION

DESCRIPTION OF CHANGE

Removed Gatewell Structures 307 and 313 and added new bid items for pipe, headwall and manhole.

JUSTIFICATION FOR CHANGE

With USIBWC concurrence, Gatewell Structures 307 and 313 were capped in lieu of reconstruction. New bid items for 24 inch RCP pipe along with a manhole and a 24 inch headwall were added to the contract in order to drain water from one side of the access ramp to the other adjacent to Gatewell Structure 313.

ENGINEER'S JUSTIFICATION OF COST

Engineer's original "Opinion of Cost" was estimated at \$22,358.05 for Bid Items 39, 40 and 41, while Contractor's offer came in at \$41,787.50 which was higher than our original estimate. Engineer underestimated how much material and equipment was necessary to complete this scope of work, and based upon a review of the Contractor's backup information, Engineer has revised our "Opinion of Cost" for Bid Items 39, 40 and 41, and recommends execution of this change order for a net decrease of \$92,407.80.

HIDALGO COUNTY

JUL 07 2009

DRAINAGE DISTRICT #1

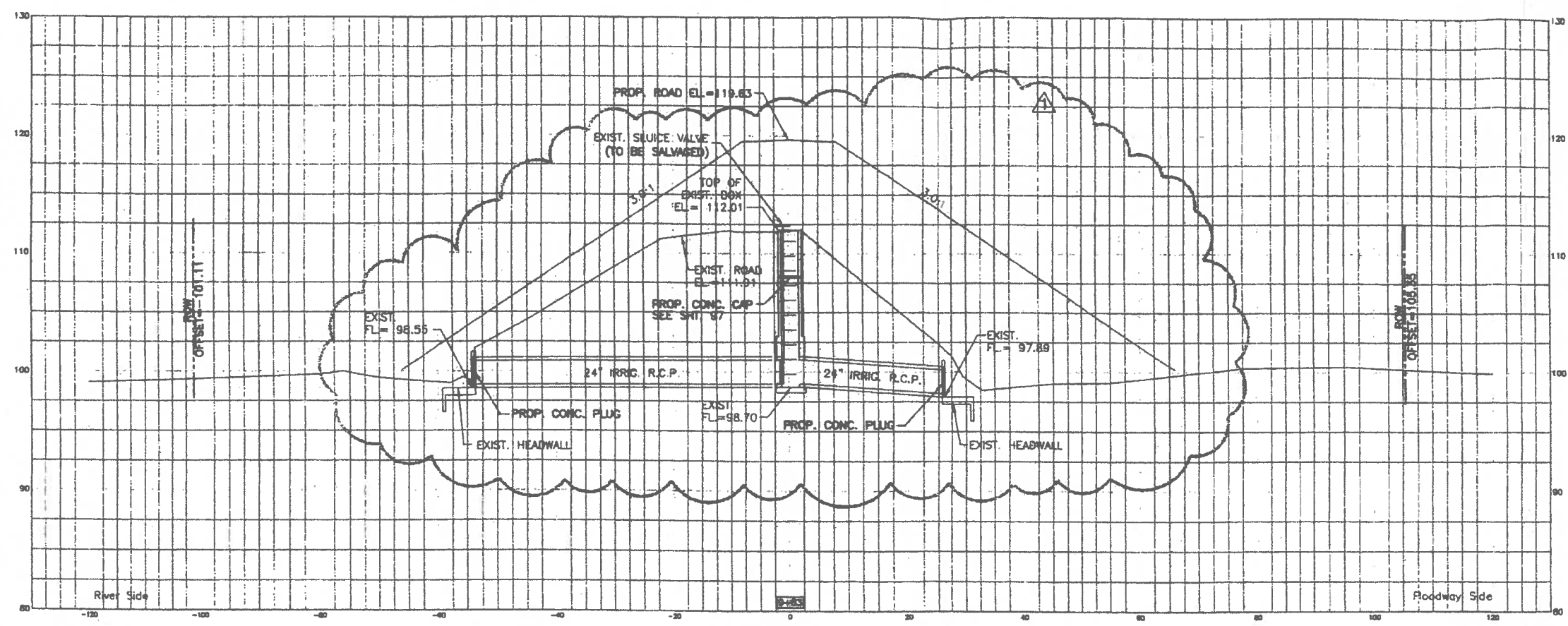

CROSS SECTIONS ARE FOR CONTRACTOR'S REFERENCE ONLY. THESE QUANTITIES DO NOT INCLUDE BENCHING OR PAVING. CONTRACTOR TO VERIFY ALL QUANTITIES.

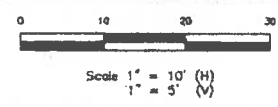

STRUCTURE No. 313

 Jose G. Reyes Jr.
 Licensed Professional Engineer # 93827
 SEP. 26, 2008



Project:  COMMON LEVEE/ ANZALDUAS DIKE IMPROVEMENTS PROJECT 

Sheet Title: COMMON LEVEE IMPROVEMENTS
 LEVEE GATEWELL
 STRUCTURE No. 313
 STA. 9+83

DLINC
 DOS LOGISTICS, INC.

212 W. 3rd. Street Phone: (958) 988-8800
 Westaco, Tx. 78686 Fax: (958) 447-8194

DANNENBAUM
 ENGINEERING COMPANY McALLEN, LLC
 1108 Marina Loop, Suite 208 McAllen, TX, 78504 (361) 682-3577

 ISSUED FOR CONSTRUCTION 9-4-08
 REVISION No.1 9-28-08
 REVISED AS NOTED

Date: Sep 26, 2008	Drawn By: E.S. J.M.
Designed By: H.P.G.	Checked By: H.P.G.
Project No.: 4287-04	Sheet: 81 of 111

CROSS SECTIONS ARE FOR CONTRACTOR'S REFERENCE ONLY. THESE QUANTITIES DO NOT INCLUDE BENCHING OR FINING. CONTRACTOR TO VERIFY ALL QUANTITIES

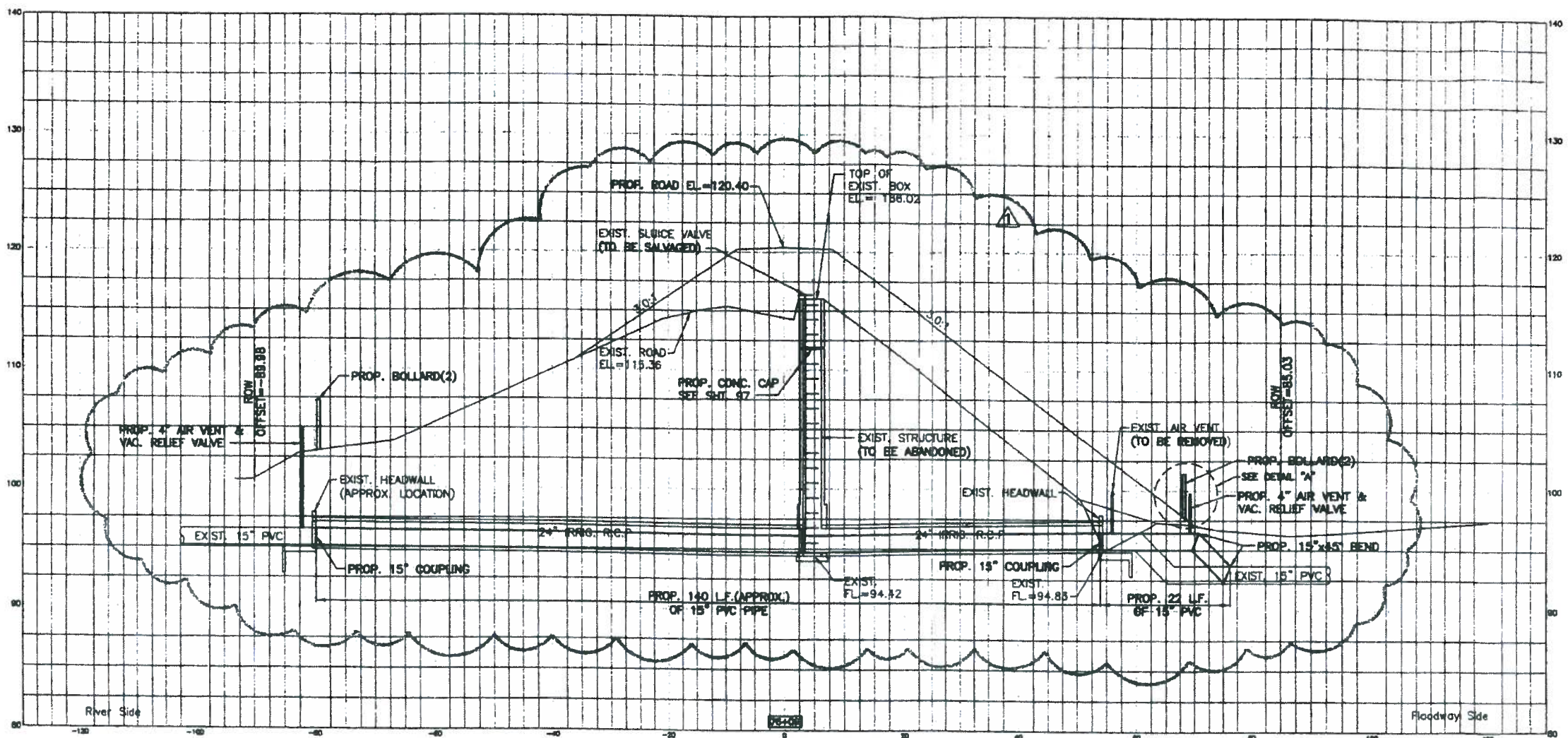

STRUCTURE No. 307



DETAIL "A"

SERIES 3000- AIR VENT & VACUUM RELIEF VALVE
N.T.S.

ISSUED FOR CONSTRUCTION 6-4-08
REVISION No.1 9-28-08
REVISED AS NOTED

Professional Engineer Seal for Jose G. Reyes Jr., License No. 93827, State of Texas. Date: Sep 26, 2008.

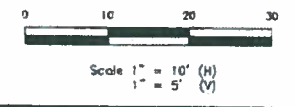

Project: COMMON LEVEE/ ANZALDUAS DIKE IMPROVEMENTS PROJECT
HCDD-1

Sheet Title: COMMON LEV IMPROVEMENTS
LEVE ATEWELL
STRUC E No. 307
S 76+09

DL INC.
DOS LOGISTICS, INC.

212 W. 3rd Street Phone: (866) 866-8800
Westaco, Tx. 78598 Fax: (866) 447-8194

DANNENBAUM
ENGINEERING COMPANY-McALLEN, LLC
1109 Nolans Loop, Suite 208 McAllen, TX 78504 (956) 682-3177

Date: Sep 26, 2008	Drawn By: E.S., J.M.
Designed By: H.P.G.	Checked By: H.P.G.
Project No.: 4287-04	Sheet: 87 of 111

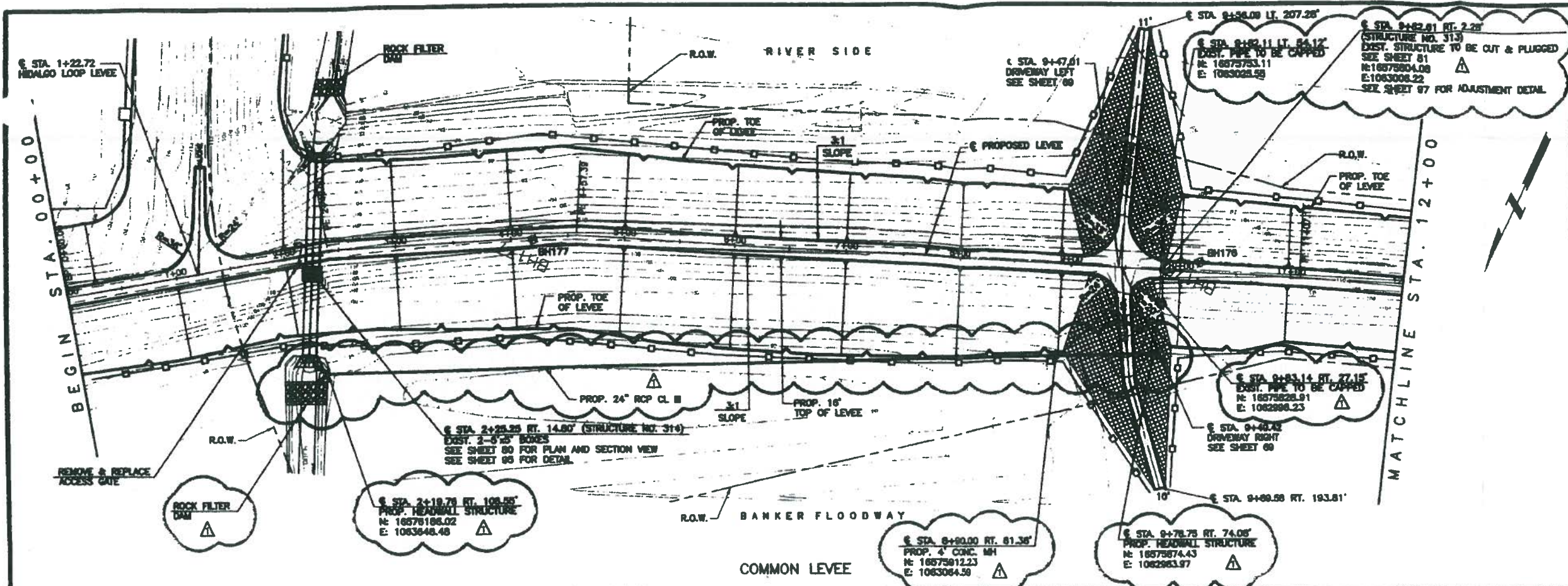

Rev. No.	Description	Chk. By:	Date
1	REVISION No. 1	R.S.	10-08-08

LEGEND

- PROPOSED METALBEAM GUARDRAIL w/POST
- PROPOSED SEDIMENT CONTROL FENCE
- ⊕ EXISTING GEOTECHNICAL BORE
- PL— EXISTING OVERHEAD POWERLINE
- ✓ PROPOSED GATE
- EXISTING GUARDRAIL w/POST
- ▨ PROPOSED LEVEE ACCESS DRIVE EMBANKMENT
- ▩ PROPOSED PAVING LIMITS
- ▧ PROPOSED STONE RIP-RAP
- ▦ EXIST. STONE RIP-RAP

NOTE:

- WHERE R.O.W. IS LESS THAN 15 FEET FROM TOE OF PROPOSED LEVEE, SEDIMENT CONTROL FENCE SHALL BE PLACED AT R.O.W. LIMITS.
- R.O.W. LEVEE SHOWN WHERE IT LIES WITHIN PLAN VIEW.
- WSE = WATER SURFACE ELEVATION
- F.G. = FINISHED GRADE

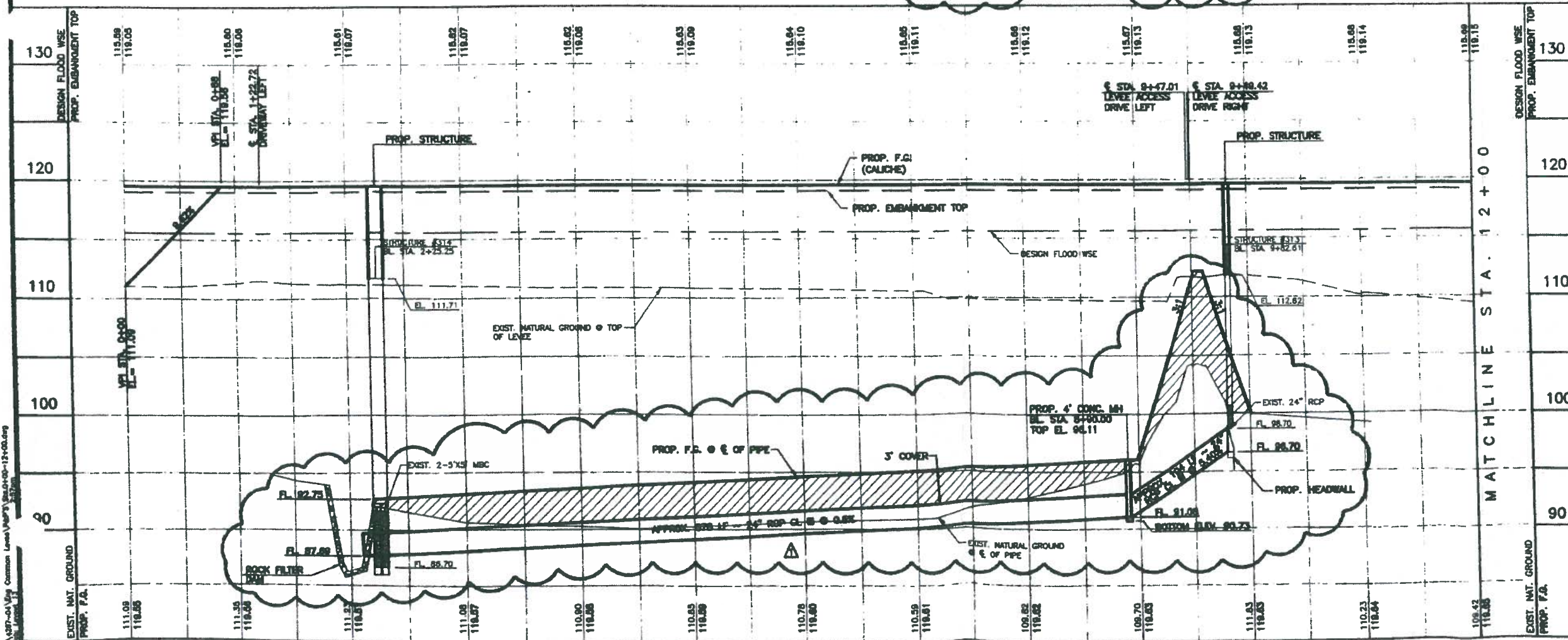

Professional Engineer Seal for Omar Anzaldo, License # 97249, dated 10-8-08.

Scale: Full Size Scale 1" = 50' (H), 1" = 5' (V)

Project: COMMON LEVEE/ ANZALDUAS DIKE IMPROVEMENTS PROJECT

Sheet Title: COMMON LEVEE IMPROVEMENTS PLAN & PROFILE STA. 0+00 - 12+00

DANNENBAUM
ENGINEERING COMPANY-McALLEN, LLC
1109 Mohrman Loop, Suite 205 McAllen, TX 78504 (956) 682-3877

Date: Oct 08, 2008
Designed By: O.A.
Checked By: H.R.V.
A.C.F.

HIDALGO County Drainage District No. 1
LEVEE IMPROVEMENTS PROJECT
COMMON LEVEE (5.35 MILES)

CHANGE ORDER NO. 3

Date: July 1, 2009

Contractor: Ballenger Construction Company
24200 North FM 509
Harlingen, Texas 78550

Owner: Hidalgo County Drainage District No. 1
902 N. Doolittle Road
Edinburg, Texas 78541

Reference: LEVEE IMPROVEMENTS PROJECT
COMMON LEVEE (5.35 MILES)

Contract No. 08-007-05-27
Dannenbaum No. 4287-04

Description:

Extension of contract time.

Contract Amount:

Original Contract Price:

Previous Change Order(s):	\$ 7,593,164.28
Contract price prior to this change order:	\$ (164,475.78)
Net increase (decrease) from this change order:	\$ -
Contract price with all change orders to date (including this change order):	\$ 7,428,688.50

Contract Time:

Authorized contract time change:

Previous Total	201	days
This Change Order	11	days
Total to Date	<u>212</u>	days

Original Contract Date
Revised Contract Date - This Change Order

Substantial Completion

12/31/2008
1/11/2009

APPROVALS:

ENGINEER:

Dannenbaum Engineering Company - McAllen, LLC

Richard D. Seitz, P.E. Date 6/30/09
Resident Project Representative

OWNER:

Hidalgo Co. Drainage Dist. No. 1

JD Salinas Date
Chairman of the Board

ACCEPTED:

CONTRACTOR:

Ballenger Construction Company

Joe C. Ballenger Jr. Date 7/2/09
President

HIDALGO COUNTY
JUL 07 2009
DRAINAGE DISTRICT #1

Weather Delays Reconciliation Sheet
Common Levee Phase III, Hidalgo Loop Levee to Anzalduas Dam
Ballenger Construction Co.

The milestones pertinent to this contract are as follows:

- | | |
|----------------------|-----------|
| 1. Bid Opening | May 21 08 |
| 2. Award | May 27 08 |
| 3. Notice to Proceed | Jun 13 08 |
| 4. Start of Work | Jun 23 08 |

Tabulation of Weather Delays, As Of January 31, 2009

Month	Expected Days Lost	Contractor Rain Days	Inspector Daily Report	Allowed Weather Days
June	4	0	0	0
July	3	6	6	3
August	3	2	3	0
September	5	6	5	0
October	3	2	2	0
November	2	1	1	0
December	2	1	1	0
January	2	0	0	0
Total				3

- | | |
|-------------------------------------------------------------------------------|---------|
| 1. Allowed Weather Delays | 3 Days |
| 2. IBWC Directive to Evacuate levees of workers and Equipment, 21-26 July 08* | 6 Days |
| 3. HCDD No. 1 directive to Evacuate Levees and Equipment, 27-28 Sep 08* | 2 Days |
| Total Days Due Contractor | 11 Days |

Revised Milestone Dates:

- | | |
|-------------------------------------------|-----------|
| 1. Substantial Completion as Advertised | Dec 31 08 |
| 2. Revised Substantial Completion per WCD | Jan 11 09 |
| 3. Final Completion Date as Advertised | Feb 28 09 |
| 4. Revised Final Completion Date per WCD | Mar 11 09 |

*Since the Contractor was directed to evacuate the work area in both events, this situation was beyond the Contractor's control and the days lost cannot be reduced by the anticipated weather delays in the Contract.

HIDALGO COUNTY
 JUL 07 2009
 DRAINAGE DISTRICT #1

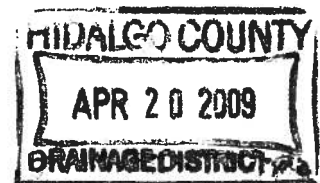

HIDALGO COUNTY DRAINAGE DISTRICT NO. 1
LEVEE IMPROVEMENTS PROJECT

CHANGE ORDER NO. 3

ATTACHMENT B

Date: July 7, 2009

Contractor: BALLENGER CONSTRUCTION
CO.
24200 North FM 509
Harlingen, Texas 78550

Owner: Hidalgo County Drainage District No. 1
902 N. Doolittle Road
Edinburg, Texas 78541

Reference: MISSION LEVEE IMPROVEMENTS
PROJECT
COMMON LEVEE / ANZALDUAS
DIKE IMPROVEMENT PROJECT
(5.35 MILES)

Contract No. 08-007-05-21

Dannenbaum No. 4287-04

ENGINEER'S EXPLANATION

DESCRIPTION OF CHANGE

Added 11 days to contract calendar days from 250 to 261 days.

JUSTIFICATION FOR CHANGE

Contractor lost 3 days due to inclement weather in July and 8 days due mandatory evacuation of levees per IBWC directive due to Hurricane Dolly.

ENGINEER'S JUSTIFICATION OF COST

N/A.

HIDALGO COUNTY

JUL 07 2009

DRAINAGE DISTRICT #1

AI-16465

5.

**Capital Improvement Plan
DRAINAGE DISTRICT**

Date: 07/14/2009

Submitted By: Sergio Cruz, BUDGET & MANAGEMENT

Department: BUDGET & MANAGEMENT

Information

CAPTION

Discussion, consideration, and possible action on Capital Improvement Plan, including but not limited to: CIP Process, Capital Projects, and the Financing of Capital Projects.

BACKGROUND

Fiscal Impact

Attachments

No file(s) attached.

Form Routing/Status

Route Seq	Inbox	Approved By	Date	Status
1	Budget & Management	Erika Zamora	07/10/2009 03:25 PM	APRV
2	Sylvia Solis	Sylvia Solis	07/10/2009 04:11 PM	APRV
3	Final Approval		07/10/2009 05:06 PM	NEW

Form Started By: Sergio Cruz
Started On: 07/10/2009 02:08 PM

Final Approval Date: 07/10/2009

**Work Authorizations and Direct Deposit/Employment Procedures
DRAINAGE DISTRICT**

Date: 07/14/2009
Submitted By: Jaime Salazar, DRAINAGE DISTRICT
Submitted For: Sylvia Sanchez
Department: DRAINAGE DISTRICT

Information

CAPTION

- A. Approval of revised Supplemental Agreement #3 as it relates to Master Drainage System Phase II - Raymondville outfall system.
- B. Approval of Final Payment to G.O. Excavating Construction for "McColl Rd. Mission Inlet Crossing".
- C. Approval to release final retainage to G.O. Excavating for "Mercedes Drain".
- D. Approval on the Hidalgo County Drainage District No.1 Pre-Enrollment & Enrollment Policy and Procedures.
- E. Approval on Hidalgo County Drainage District No.1 Direct Deposit Policy and Procedures.

BACKGROUND

Fiscal Impact

Attachments

- Link: [Final pmt McColl Rd Mission](#)
- Link: [Retainage release](#)
- Link: [Supplemental Agreement #3](#)

Form Routing/Status

Route	Seq	Inbox	Approved By	Date	Status
1		Budget & Management	Erika Zamora	07/09/2009 08:31 AM	APRV
2		Sylvia Solis	Sylvia Solis	07/10/2009 01:06 PM	APRV
3		Final Approval		07/10/2009 05:06 PM	NEW
Form Started By: Jaime Salazar				Started On: 07/08/2009 02:11 PM	
Final Approval Date: 07/10/2009					

APPLICATION FOR FINAL PMT

To: HIDALGO COUNTY DRAINAGE DISTRICT No. 1 (OWNER)
 From: GO Excavating and Construction (CONTRACTOR)
 Contract: DD 08-002-04-14
 Project: McColl Rd. Mission Inlet Crossing
 OWNER's Contract No. DD 08-002-04-14 ENGINEER's Project No. ENG07.047
 For Work accomplished through the date of: 20-Jan-2009

1. Original Contract Price:		\$ 377,959.09
2. Net change by Change Orders and Written Agreements (+ or -):		\$ 39,596.50
3. Current Contract Price (1 plus 2):		\$ 417,555.59
4. Total completed and stored to date:		\$ 417,555.59
5. Retainage (per Agreement):		
10% of completed Work:	\$ 41,755.56	
10% of stored material:	\$ -	
Total Retainage:		\$ 41,755.56
6. Total completed and stored to date less retainage (4 minus 5):		\$ 375,800.03
7. Less previous Application for Payments:		\$ (224,572.50)
8. Balance to Finish:		\$ -
9. AMOUNT DUE THIS APPLICATION (6 MINUS 7):		\$ 151,227.53

Accompanying Documentation:

CONTRACTOR'S Certification:

The undersigned CONTRACTOR certifies that (1) all previous progress payments received from OWNER on account of Work done under the Contract referred to above have been applied on account to discharge CONTRACTOR's legitimate obligations incurred in connection with Work covered by prior Applications for Payment numbered 1 through FINAL PMT inclusive; (2) title of all Work, materials and equipment incorporated in said Work or otherwise listed in or covered by this Application for Payment will pass to OWNER at time of payment free and clear of all Liens, security interests and encumbrances (except such as are covered by a Bond acceptable to OWNER indemnifying OWNER against any such Lien, security interest or encumbrance); and (3) all Work covered by this Application for Payment is in accordance with the Contract Documents and not defective.

Dated 24-Feb-09 GO Excavating and Construction
 CONTRACTOR

By: Carlos Garcia

State of Texas
 County of Hidalgo
 Subscribed and sworn to before me this 1st
 day of July 2009

[Signature]
 Notary Public
 My Commission expires: 12/16/2011



Payment of the above AMOUNT DUE THIS APPLICATION is recommended.

Dated 24-Feb-09 R. GUTIERREZ ENGINEERING CORPORATION
 ENGINEER

By: [Signature] P.E. 6/30/09

CCM
7/1/09

R. Gutierrez Engineering Corporation

February 24, 2009

Mr. Godfrey Garza
Hidalgo County Drainage District # 1
Drainage District Manager
902 N. Doolittle Rd.
Edinburg, Texas 78539

Subject: McColl Road.Mission Inlet Crossing

Dear Mr. Garza:

The McColl Road Mission Inlet Crossing work has been completed in accordance with the plans and specifications and all addenda, change orders, supplemental agreements. The McColl Road Mission Inlet Crossing on the McColl Road was accepted as accomplished on January 23, 2009. The contractor has presented a "Certificate of Release" stating under oath, that all claims arising out of the performance of work have been fulfilled, and the Owner is released from all claims arising under or by virtue of said contract. The Contractor has presented in behalf of itself and its sureties, satisfactory evidence that it is bound to repair, replace, and make good any faulty workmanship and/or materials discovered in the work within a period of one year from this date, as provided in said contract.

If you have any questions, comments, or additional concerns, please feel free to contact me at (956) 782-2557. Thank You.

Sincerely

Luis J. Maya, P.E.
Senior Project Manager

cc. Claudette Cavazos, HCDD No.1, Contract Manager

Application: FINAL PMT
 Application Date: 24-Feb-2009
 Period To: 20-Jan-2009
 Engineer Firm: R. Gutierrez Eng. Corp.

Summary

Description	Original Schedule Value	C.O. #1 Schedule Value	Application #1	Retainage for App #1	Payment for Application #1	Final Application	Retainage for Final App	Payment for Final Application	Total Completed to Date	Retainage to Date	Total Completed Less Retainage	Previous Payments	Balance To Finish
Session Inlet Cross	\$ 377,959.09	\$ 417,555.59	\$ 249,525.00	\$ 24,952.50	\$ 224,572.50	\$ 168,030.59	\$ 16,803.06	\$ 151,227.53	\$ 417,555.59	\$ 41,755.56	\$ 375,800.03	\$ 224,572.50	\$ -
TOTALS:	\$ 377,959.09	\$ 417,555.59	\$ 249,525.00	\$ 24,952.50	\$ 224,572.50	\$ 168,030.59	\$ 16,803.06	\$ 151,227.53	\$ 417,555.59	\$ 41,755.56	\$ 375,800.03	\$ 224,572.50	\$ -

GO Excavating and Construction
 18-Jun-2008
 6-Jan-2009
 McColl Rd. Mission Inlet Crossing

Application: FINAL PMT
 Application Date: 24-Feb-2009
 Period To: 20-Jan-2009
 Engineer's / County Project No.: ENG07.047

Unit	Original Schedule Value			Change Order #1 Revised Schedule Value			Application #1			Final Application			Balance To Finish		
	Original Rates	Quan	Dollars	Revised Rates	Quan	Dollars	Monthly Quan	QTY to Date	Item Cost (Monthly)	Monthly Quan	QTY to Date	Item Cost (Monthly)	Total to Date	Quan	Dollars
CY	\$ 5.00	849.00	\$ 4,245.00	\$ 5.00	849.00	\$ 4,245.00	370.00	370.00	\$ 1,850.00	479.00	849.00	\$ 2,395.00	\$ 4,245.00	0.000	\$ -
CY	\$ 2.50	2,258.00	\$ 5,645.00	\$ 2.50	2,258.00	\$ 5,645.00	2,258.00	2,258.00	\$ 5,645.00		2,258.00	\$ -	\$ 5,645.00	0.000	\$ -
CY	\$ 1.25	12,393.00	\$ 15,491.25	\$ 1.25	12,393.00	\$ 15,491.25	6,500.00	6,500.00	\$ 8,125.00	5,893.00	12,393.00	\$ 7,366.25	\$ 15,491.25	0.000	\$ -
SY	\$ 0.85	3,150.00	\$ 2,677.50	\$ 0.85	3,150.00	\$ 2,677.50			\$ -	3,150.00	3,150.00	\$ 2,677.50	\$ 2,677.50	0.000	\$ -
LF	\$ 4.00	392.00	\$ 1,568.00	\$ 4.00	392.00	\$ 1,568.00			\$ -	392.00	392.00	\$ 1,568.00	\$ 1,568.00	0.000	\$ -
CY	\$ 475.00	236.00	\$ 112,100.00	\$ 475.00	236.00	\$ 112,100.00	236.00	236.00	\$ 112,100.00		236.00	\$ -	\$ 112,100.00	0.000	\$ -
CY	\$ 425.00	156.00	\$ 66,300.00	\$ 425.00	156.00	\$ 66,300.00	30.00	30.00	\$ 12,750.00	126.00	156.00	\$ 53,550.00	\$ 66,300.00	0.000	\$ -
CY	\$ 440.00	117.00	\$ 51,480.00	\$ 440.00	117.00	\$ 51,480.00	117.00	117.00	\$ 51,480.00		117.00	\$ -	\$ 51,480.00	0.000	\$ -
LF	\$ 245.00	235.00	\$ 57,575.00	\$ 245.00	235.00	\$ 57,575.00	235.00	235.00	\$ 57,575.00		235.00	\$ -	\$ 57,575.00	0.000	\$ -
LF	\$ 35.31	474.00	\$ 16,736.94	\$ 35.31	474.00	\$ 16,736.94			\$ -	474.00	474.00	\$ 16,736.94	\$ 16,736.94	0.000	\$ -
EA	\$ 750.00	4.00	\$ 3,000.00	\$ 750.00	4.00	\$ 3,000.00			\$ -	4.00	4.00	\$ 3,000.00	\$ 3,000.00	0.000	\$ -
EA	\$ 2,950.00	1.00	\$ 2,950.00	\$ 2,950.00	1.00	\$ 2,950.00			\$ -	1.00	1.00	\$ 2,950.00	\$ 2,950.00	0.000	\$ -
LF	\$ 6.20	192.00	\$ 1,190.40	\$ 6.20	192.00	\$ 1,190.40			\$ -	192.00	192.00	\$ 1,190.40	\$ 1,190.40	0.000	\$ -
SY	\$ 10.00	3,400.00	\$ 34,000.00	\$ 10.00	3,400.00	\$ 34,000.00			\$ -	3,400.00	3,400.00	\$ 34,000.00	\$ 34,000.00	0.000	\$ -
EA	\$ 500.00	6.00	\$ 3,000.00	\$ 500.00	6.00	\$ 3,000.00			\$ -	6.00	6.00	\$ 3,000.00	\$ 3,000.00	0.000	\$ -
CY	\$ -	0.00	\$ -	\$ -	0.00	\$ -			\$ -	824.00	824.00	\$ 13,184.00	\$ 13,184.00	0.000	\$ -
CY	\$ -	0.00	\$ -	\$ -	0.00	\$ -			\$ -	824.00	824.00	\$ 20,600.00	\$ 20,600.00	0.000	\$ -
SY	\$ -	0.00	\$ -	\$ -	0.00	\$ -			\$ -	2,325.00	2,325.00	\$ 5,812.50	\$ 5,812.50	0.000	\$ -
Total Drainage			\$ 377,959.09			\$ 417,555.59			\$ 249,525.00			\$ 168,030.59	\$ 417,555.59		\$ -
TOTAL AMOUNTS:			\$ 377,959.09			\$ 417,555.59			\$ 249,525.00			\$ 168,030.59	\$ 417,555.59		\$ -

Printed Name:

Javier Gutierrez

Date:

24-Feb-2009

Signature:



APPLICATION FOR RETAINAGE RELEASE

To: HIDALGO COUNTY DRAINAGE DISTRICT No. 1 (OWNER)
 From: GO Excavating and Construction (CONTRACTOR)
 Contract: DD 08-002-04-14
 Project: McColl Rd. Mission Inlet Crossing
 OWNER's Contract No. DD 08-002-04-14 ENGINEER's Project No. ENG07.047
 For Work accomplished through the date of: 20-Jan-2009

1. Original Contract Price:	\$ 377,959.09
2. Net change by Change Orders and Written Agreements (+ or -):	\$ 39,596.50
3. Current Contract Price (1 plus 2):	\$ 417,555.59
4. Total completed and stored to date:	\$ 417,555.59
5. Retainage (per Agreement):	
<u>0%</u> of completed Work:	\$ -
<u>0%</u> of stored material:	\$ -
Total Retainage:	\$ -
6. Total completed and stored to date less retainage (4 minus 5):	\$ 417,555.59
7. Less previous Application for Payments:	\$ (417,555.59)
8. Balance to Finish:	\$ -
9. AMOUNT DUE THIS APPLICATION (6 MINUS 7):	\$ -

Accompanying Documentation:

CONTRACTOR'S Certification:

The undersigned CONTRACTOR certifies that (1) all previous progress payments received from OWNER on account of Work done under the Contract referred to above have been applied on account to discharge CONTRACTOR's legitimate obligations incurred in connection with Work covered by prior Applications for Payment numbered 1 through RETAINAGE RELEASE inclusive; (2) title of all Work, materials and equipment incorporated in said Work or otherwise listed in or covered by this Application for Payment will pass to OWNER at time of payment free and clear of all Liens, security interests and encumbrances (except such as are covered by a Bond acceptable to OWNER indemnifying OWNER against any such Lien, security interest or encumbrance); and (3) all Work covered by this Application for Payment is in accordance with the Contract Documents and not defective.

Dated 24-Feb-09 GO Excavating and Construction
 CONTRACTOR

By: Carlos Gierzen

State of Texas
 County of Hidalgo

Subscribed and sworn to before me this 1st
 day of July 2009

[Signature]
 Notary Public
 My Commission expires: 12/16/2011



Payment of the above AMOUNT DUE THIS APPLICATION is recommended.

Dated 24-Feb-09 R. GUTIERREZ ENGINEERING CORPORATION
 ENGINEER

By: [Signature] P.E. 6/30/09

ion

Application: RETAINAGE RELEASE
 Application Date: 24-Feb-2009
 Period To: 20-Jan-2009
 Engineer Firm: R. Gutierrez Eng. Corp.

Summary													
Description	Original Schedule Value	C.O. #1 Schedule Value	Application #1	Retainage for App #1	Payment for Application #1	Final Application	Retainage for Final App	Payment for Final Application	Total Completed to Date	Retainage to Date	Total Completed Less Retainage	Previous Payments	Balance To Finish
Session Inlet Cross	\$ 377,959.09	\$ 417,555.59	\$ 249,525.00	\$ -	\$ 249,525.00	\$ 168,030.59	\$ -	\$ 168,030.59	\$ 417,555.59	\$ -	\$ 417,555.59	\$ 417,555.59	\$ -
TOTALS:	\$ 377,959.09	\$ 417,555.59	\$ 249,525.00	\$ -	\$ 249,525.00	\$ 168,030.59	\$ -	\$ 168,030.59	\$ 417,555.59	\$ -	\$ 417,555.59	\$ 417,555.59	\$ -



GO underground LLC

June 24, 2009

GO Underground LLC
217 E Monroe
Harlingen TX 78550

R. Gutierrez Engineering Corporation
Luis J. Nava, PE.
Senior Project Manager

Re: McColl Rd. Mission Inlet Crossing

Dear Mr. Nava:

Go Underground LLC has successfully completed this project since Dec 23, 08, based on this project warranty for one year on the work performed by GO Underground LLC excluding the materials provided to us. On this project 2 other Engineers were involved for the Aluminum Arch and the stabilization for the footing in which GO Underground LLC performed the work of installation according to the specs. Warranty in effect until Dec 23, 09.

A handwritten signature in black ink, appearing to read 'George Olivas', written over a horizontal line.

George Olivas Owner and Gen. Manager

FINAL RELEASE

G.O. EXC. & CONSTRUCTION
217 E. MONROE AVE.
HARLINGEN, TX 78550

Re: McCOLL RD. MISSION INLET

Southern Star Transport, LTD. Waives and releases any lien for all materials furnished to for the use on the G.O. EXC. CONST. project commonly known as:

McCOLL RD. MISSION INLET AMOUNT DUE \$0.00 AS OF 2/30/09

Located in Hidalgo County, Texas, Southern Star Transport, LTD acknowledges that all payments received on amount of materials furnished to the project have been accepted in full satisfaction of the liens or right to lien, waived hereunder.

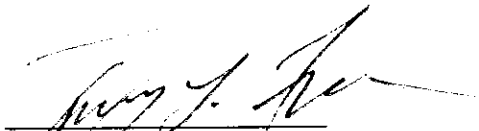

Southern Star Transport, LTD
Tommy L. Freeman

STATE OF TEXAS
COUNTY OF HIDALGO

Subscribed and sworn to before me, the undersigned authorities, on this the 23rd day of June, 2009 to certify which, witness my hand and seal of office.



Notary Public, State of Texas

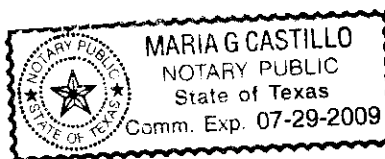

FINAL WAIVER OF LIEN

The undersigned hereby acknowledge that the amount of

\$ 2,326.00

was received from

G.O. Excavating & Construction

Company Name

As Progress Payment for the following goods and / or services:

Rebar

Performed at the project described as:

McColl Rd Mission Inlet Crossing Bid#DD 08-002-01-30

The undersigned hereby waives the right to assert a lien and release any lien against owner to this extent only. This lien waiver does not affect the right of the undersigned recover payment for any other goods or services supplied before or after this release date not compensated by the progress payment or any rights which the undersigned may have by contract.

Mil Finch, Credit Analyst

Name of Claimant and Title

CMC VALLEY STEEL

Company Name

P.O. Box 3195, Austin, TX 78764

Company Address

6-24-09

Date

Mil Finch Milan Finchem

Signature

FINAL RELEASE

G.O. EXC. & CONSTRUCTION
217 E. MONROE AVE.
HARLINGEN, TX 78550

Re: McCOLL RD MISSION INLET

Rio Valley Pipe LLC waives and releases any lien for all materials furnished to for the use on the G.O. EXC. CONST. project commonly known as:

McCOLL RD MISSION INLET AMOUNT DUE \$0.00 AS OF 2/30/09

Located in Hidalgo County, Texas. Rio Valley Pipe, LLC acknowledges that all payments received on amount of materials furnished to the project have been accepted in full satisfaction of the liens or right to lien, waived hereunder.

Edgar Mercedes
Rio Valley Pipe, LLC

STATE OF TEXAS
COUNTY OF Hidalgo

Subscribed and sworn to before me, the undersigned authority, on this the 12th day of June, 2009 to certify which, witness my hand and seal of office.

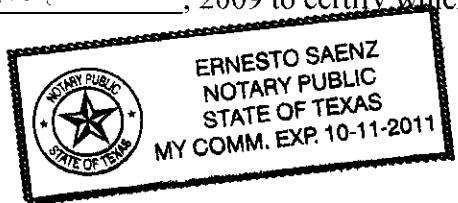

[Signature]
Notary public, State of Texas

My commission expires 10-11-2011

[Signature]
Notary's Name Printed



Fabricators of Reinforcing Steel

Edinburg
U S 281 @ E Owassa
Edinburg, TX 78539
(956) 702-4434

San Benito
2701 E Bus 77
San Benito, TX 78586
(956) 361-4443

Shepler's
Serving Texas Contractors Since 1947

RELEASE OF LIEN

February 20, 2009

Rio Grande Steel, Ltd., contracted to furnish reinforcing steel and/or miscellaneous concrete supplies for the construction of **McColl Rd., Mission INLET, Hidalgo County, Texas** constructed for **G.O. Excavating Construction**.

I do hereby declare the above described real estate released and discharged from liens created because of construction on the above-described work, to the extent of construction so far completed; and, by these presents. I do fully release, discharge and quitclaim unto the said owner, his heirs or assigns, all the right, title, interest and estate in and to the property above described. The release includes all labor and materials for which a lien could be filed, to the extent described.

Release is for the worth of payment received to date and excludes ____-0-____

By: _____
J. Arturo Montelongo/Accountant

The State of Texas, County of Hidalgo, Before me, the undersigned authority, on this day personally appeared, **J. Arturo Montelongo**, known to be the person whose name is subscribed to the foregoing instrument, and acknowledged to me that he executed the same for the purpose and consideration expressed therein.

Given my hand and seal of office this 20th.day of **February** 2008.

Pedro Cruz, Jr., Notary Public

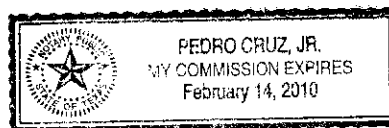



Final Lien Release

Date: June 23, 2009

Supplier's/Subcontractor's Release and Certification of Payment for Materials Supplied to:

Customer: G O Excavating Project Name: McColl
Project Address: McAllen, TX 78501
Invoice Numbers: 2440406, 2484866

FOR VALUABLE CONSIDERATION, the sufficiency and receipt of which is acknowledge, the undersigned acknowledges payment specified below, and waives, releases, and relinquishes all rights and claims (including mechanic's lien rights, claims under public works statues, claims against bonds and other rights afforded by law to protect unpaid subcontractors, laborers and suppliers of machinery tools, equipment, materials, supplies, services and other items used in construction) against the project or other party who has an interest in that project thru December 31, 2008.

THE UNDERSIGNED certifies and represents that all labor, services, material, tools, equipment, supplies and like furnished by the undersigned for incorporation in, or use on, the above named project or has been included in the invoices listed and amount specified below thru December 31, 2008.

THIS RELEASE and representations made above are made with the intent that the project owner, general contractor, and any bonding company or any other party whose property might be liable for any claims of the undersigned may relay on the language of this instrument. This Release and the representations made above are made with the intent that the Subcontractor/Supplier waives and relinquishes all claims against General Contractor and Project Owner in connection with this project for the invoices described herein and/or attached hereto thru December 31, 2008.

IT IS FURTHER AGREED that the release of monies does not constitute final acceptance or release the Subcontractor/Supplier from his obligations under the Contract until the final acceptance of this project is made by the Owner.

SUPPLIER/SUBCONTRACTOR:

BY: [Signature]
(Authorized Company Representative)

TITLE: Terri Long Mgr

State of Texas
County of Hidalgo

Acknowledged before me this 24th day of June, 2009

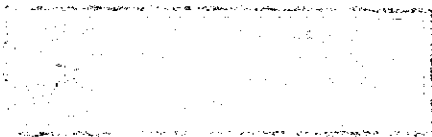

[Signature]
(Notary Public)

Partial Waiver of Lien

To whom it may concern:

WHEREAS, the undersigned **Magic Valley Concrete, LLC** has been employed by **G.O. EXCAVATING** to furnish labor and/or materials for the **HD CITY PREC. #2 McCOLL ROAD & RIDGE ROAD** Items for the construction at **HD CITY PREC. #2 McCOLL ROAD & RIDGE ROAD Rd. Drainage** in **McALLEN, TX**.

NOW, THEREFORE, for and in consideration of and other valuable considerations, the receipt whereof is hereby acknowledge, the undersigned does hereby waive and release any and all lien or claim or right of lien on the above described premises and the improvements thereon, under the Statutes of the State in which the aforesaid building is located relating to mechanics' liens, and on the monies or other consideration due or to become due from the owner, and on account of labor or materials, or both, or which may be furnished by the undersigned to or on account of the said individual or firm therein named for the said premises or improvements.

Balance Remaining with Rio Valley Pipe for this Project: \$ 0.00

Dated: 6-23-09

NOTORIZATION REQUIRED

Magic Valley Concrete, LLC
(Company Name)

State of TEXAS

County of HIDALGO

By: [Signature]
(Signature of Sole Owner or Company Officer)

Signed and sworn to before me this 23rd day of JUNE, 2009

A/R MGR.
(Title)

[Signature]
(Notary Public Signature)

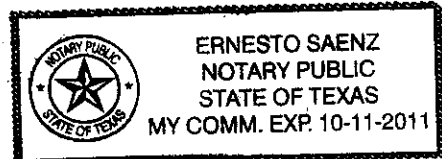

My Commission Expires 10-11-2011

WAIVER, RELEASE AND DISCHARGE

Certificate and Affidavit made this 23rd day of June, 2009. By FRONTERA **MATERIALS, INC.** (“Releasor”), a subcontractor/supplier to **G.O. UNDERGROUND, LLC.** (“Contractor”) relating to a relationship and/or Contract for the performing and/or furnishing of work, labor, services, materials, and/or equipment in connection with a Prime Contract and Project known as McColl Road Mission Inlet Crossing for and in the consideration of **TWO THOUSAND EIGHT-HUNDRED SEVENTY-FOUR DOLLARS AND THIRTY-SIX CENTS (\$2874.36)**, and other good valuable consideration, which sum is acknowledged as being the final and total amount due or alleged due or owing from the Contractor, it’s sureties _____ and all other guarantors on any performance, payment, labor, and/or material bond or other undertaking, (hereinafter collectively referred to as a “Releasee”) the receipt of which, by Releasor from Releasee, and payment thereof, is hereby acknowledged; the Releasor for an on behalf of itself and all parties claiming any discharge the Releasee from all caused of action, suits, debts, accounts, bonds, contracts, promises, damages, liens, encumbrances, judgments, claims and demands whatsoever, in law or equity, which against the Releasee, jointly or separately, the Architect/Engineer and the Owner of the Project, Releasor ever had, now has, or might hereinafter have, relating directly or indirectly to the aforesaid relationship, Contract, Prime Contract and/or Project.

The Releasor hereby agrees to indemnify and hold the Releasee harmless from any and all damage, costs, expenses, demands, suits, liens, and legal fees, directly of or indirectly relating to any claim for compensation by any other party for work, labor, services, materials, and/or equipment which directly or indirectly relates to that which was performed or should have been performed by the Releasor, and from against any claim relating to work, labor, services, materials and/or equipment allegedly performed by the Releasor.

The Releasor hereby certifies and warrants with that it has fully paid for all work, labor, services, materials and/or equipment provided to it in connection with the Contract, Prime Contract and/or Project. The Releasor hereby grants to the Contractor the right to review and audit any and all books and records of the Releasor at any time for verification.

FRONTERA MATERIALS, INC.

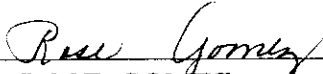

BY: ROSE GOMEZ

DATE: 6/23/09 TITLE: Office Administrator

R. Gutierrez Engineering Corporation

Certificate of Substantial Completion

PROJECT: McCOLL RD. MISSION INLET CROSSING
PROJECT NUMBER: ENG07.047
OWNER: HIDALGO COUNTY DRAINAGE DISTRICT No. 1
CONTRACTOR: GO EXCAVATION AND CONSTRUCTION

The Work performed under this Contract has been reviewed and found, to the Engineer's best knowledge, information and belief, to be substantially complete. Substantial Completion is the stage in the progress of the Work when the Work or designated portion is sufficiently complete in accordance with the Contract Documents so that the owner can occupy or utilize the Work for its intended use. The date of Substantial Completion of the Project or portion designated above is the date of issuance established by this Certificate, which is also the date of commencement of applicable warranties required by the Contract Documents, except as stated below:

R. Gutierrez Engineering Corp. Luis J. Nava P.E. 12/23/2008
Engineer By *Luis J. Nava P.E.* Date of Issuance

A list of items to be completed or corrected is attached hereto. The failure to include any items on such list does not alter the responsibility of the Contractor to complete all Work in accordance with the Contract Documents. Unless otherwise agreed to in writing, the date of commencement of warranties for items on the attached list will be the date of issuance of the final Certificate of Payment or the date of final payment.

Cost estimate of Work that is incomplete or defective: \$ 29,367.90

The Contractor will complete or correct the Work on the list of items attached hereto within 30 days from the above date of Substantial Completion.

GO EXCAVATION & CONST.. *Fergel Alvarez* 12-24-08
Contractor By Date

R. Gutierrez Engineering Corporation

January 7, 2009

Mr. George Olivares
GO Excavating & Construction
217 E. Monroe Avenue
Harlingen, TX 78550

RE: McColl Road Mission Inlet (Punch list Items)

Dear Mr. Olivares:

A walkthrough was conducted on January 6, 2009 between Mr. Robert de Leon and Noe Saldivar P.E. with the Hidalgo County Drainage District No.1, Mr. Charlie and yourself with GO Excavating & Construction and Mr. Juan Uribe and myself from R. Gutierrez Engineering Corporation (R.G.E.C.), in the purpose to formulate this punch list. These comments are as follows:

1. Item 132 – Embankment needs to be completed (survey crew will be installing hubs according with construction plans).
2. Item 164 – Seeding (Perm)(Urban)(Clay)(Fert & Watering) needs to be applied.
3. Item 420 – Rubble Rip-Rap needs to be laid down according with construction plans.
4. Seal all concrete joints with epoxy to prevent damage to the structure.
5. Wood forms from concrete Rip-Rap needs to be removed and dirt needs to leveled.
6. General clean up.

If you have any questions regarding to this punch list, please call at our office (956) 782-2557.

Sincerely,

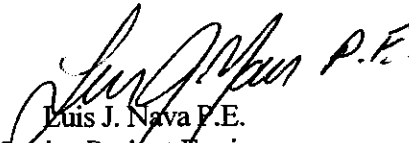
Luis J. Nava P.E.
Senior Project Engineer

cc: Mr. Godfrey Garza, Hidalgo County Drainage District No.1, Director
Noe Saldivar P.E., Hidalgo County Drainage District No.1, Engineer

PAYMENT APPLICATION

TO: *Hidalgo County Drainage District No. 1*

PROJECT NAME AND LOCATION: *Hidalgo County Drainage Imp.*

FROM: *G.O. Excavating & Construction*

ARCHITECT: *Guzman & Munoz Engineering and Surveying Inc.*

APPLICATION # *Final Retainage Release* Distribution to:
 PERIOD THRU: *release retainage* OWNER
 PROJECT #s: *08-001-01-08* ARCHITECT
 DATE OF CONTRACT: CONTRACTOR

FOR:

CONTRACTOR'S SUMMARY OF WORK

Application is made for payment as shown below.
 Continuation Pages are attached:

1. CONTRACT AMOUNT		<u>268,681.40</u>
2. SUM OF ALL CHANGE ORDERS		<u>13,774.00</u>
3. CURRENT CONTRACT AMOUNT	(Line 1 +, 2)	<u>282,455.40</u>
4. TOTAL COMPLETED AND STORED	(Column G on Continuation Page)	<u>- 0 -</u>
5. RETAINAGE:		
a. 10.00% of Completed Work	(Columns D + E on Continuation Page)	<u>0.00</u>
b. 10.00% of Material Stored	(Column F on Continuation Page)	<u>0.00</u>
Total Retainage (Line 5a + 5b or Column I on Continuation Page)		<u>0.00</u>
6. TOTAL COMPLETED AND STORED LESS RETAINAGE		<u>282,455.40</u>
7. LESS PREVIOUS PAYMENT APPLICATIONS	(Line 4 minus Line 5 Total)	<u>254,209.86</u>
8. PAYMENT DUE		<u>28,245.54</u>
9. BALANCE TO COMPLETION	(Line 3 minus Line 8)	<u>- 0 -</u>

SUMMARY OF CHANGE ORDERS	ADDITIONS	DEDUCTIONS
Total changes approved in previous months	<u>13,774.00</u>	
Total approved this month	<u>0</u>	
TOTALS	<u>13,774.00</u>	
NET CHANGES	<u>13,774.00</u>	

PAYMENT APPLICATION

Contractor's signature below is his assurance to Owner, concerning the payment herein applied for, that: (1) the Work has been performed as required in the Contract Documents; (2) all sums previously paid to Contractor under the Contract have been used to pay Contractor's costs for labor, materials and other obligations under the Contract for Work previously paid for; and (3) Contractor is legally entitled to this payment.

CONTRACTOR: *George Olivas* Date: 7-1-09
 By: *George Olivas, President*

State of: Texas
 County of: Hidalgo
 Subscribed and sworn to before me this 1st day of July 2009
 Notary Public: *[Signature]*
 My Commission Expires: 11-14-2010

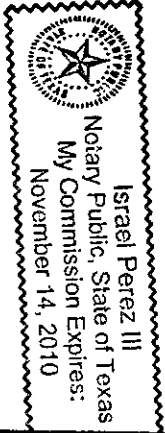

ARCHITECT'S CERTIFICATION

Architect's signature below is his assurance to Owner, concerning the payment herein applied for, that: (1) Architect has inspected the Work represented by this Application, (2) such Work has been completed to the extent indicated in this Application, and the quality of workmanship and materials conforms with the Contract Documents, (3) this Application for Payment accurately states the amount of Work completed and payment due therefor, and (4) Architect knows of no reason why payment should not be made.

CERTIFIED AMOUNT: \$28,245.54

(If the certified amount is different from the payment due, you should attach an explanation. Initial all the figures that are changed to match the certified amount.)

Engineer's *[Signature]* Date: 7/1/09
 ARCHITECT: *Jose Luis Minoz*

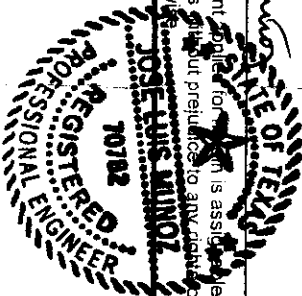

[Handwritten signature]
 7/1/09

2. **Article 5.1 Basic Services** is deleted in its entirety and the following is substituted in lieu thereof:

5.1 Basic Services. For and in consideration of the *Basic Services* to be rendered by the **Engineer**, as identified in Article 2 and more particularly identified in **EXHIBIT “B”**, attached hereto, the maximum amount payable by the **Owner** to the **Engineer** for *Basic Services*, subject to adjustment in accordance with Article 6.1 herein, is equal to nine percent (9%) of the construction cost of the Project, as mutually-agreed between the Owner and the Engineer and more particularly defined in Article 6.1 herein, (hereinafter referred to as the “**Basic Services Fee**”), plus up to an additional one-half percent (0.5%) if the **Engineer** furnishes the requirements for incentives specified in Article 5.3 herein, as more particularly described in **EXHIBIT “D2” –Funding Incentives**, attached hereto, and more particularly defined in Article 6.1 herein. An outline and breakdown of the **Basic Services Fee** is more particularly identified in **EXHIBIT “D1”-Fee Breakdown**, attached hereto and made a part of this Agreement. Payments to the **Engineer** for *Basic Services* shall be made by the **Owner**, upon presentation by the **Engineer** of the monthly **Request for Payment**, in accordance with the terms and provisions of Article 6 herein.

3. **Article 6.1 Method of Payment.** The second paragraph of Article 6.1 is deleted in its entirety and the following is substituted in lieu thereof:

Should the **Project** or portions of the **Project** be awarded for construction, the **Owner** will reconcile and determine the final maximum amount payable for the **Basic Services Fee**, as identified in Article 5.1 hereof, for that portion of the **Project** that has been awarded for construction as follows:

- (1) Construction Cost – An estimated construction cost will be developed for each phase of the project, and be updated throughout engineering (advance planning, final design and plans and specifications) development. A construction cost will be mutually agreed between the Owner and the Engineer in writing at the time of submittal of the final plans and specifications to the Owner (the “Final Estimated Construction Cost”). A fee will be calculated as nine percent (9%) of the Final Estimated Construction Cost (“Preliminary Basic Services Fee”). After the project is constructed, and the final construction cost of the project is determined, the Preliminary Basic Services Fee will be adjusted no more than plus or minus ten percent (+/- 10%) as follows:

- (a) If the final construction cost of the project is more than the Final Estimated Construction Cost, the Basic Services Fee for engineering will be adjusted up, but the adjustment will be no more than plus ten percent (+10%) of the Preliminary Basic Services Fee; or,
 - (b) If the final construction cost of the project is less than the Final Estimated Construction Cost, the Basic Services Fee for engineering will be adjusted down, but the adjustment will be no more than minus ten percent (-10%) of the Preliminary Basic Services Fee.
- (2) Incentives – The portion of the Basic Services Fee for funding incentive will be reconciled and based on funding received at the time of reconciliation.

This reconciliation and determination by the **Owner** will be performed on a yearly basis throughout the development of the **Project**, and within the period of service established in Article 3. Payment due to the **Engineer** or credit owed to the **Owner** by the **Engineer** in the amount of this reconciliation and determination shall be applied to the next applicable **Request for Payment**.

4. All terms and conditions set forth in the Agreement except as amended herein are ratified and confirmed and shall remain in full force and effect during the term of this Agreement or any extension thereof pursuant to the terms of the Agreement:

IN WITNESS WHEREOF, the **Engineer** and the **Owner** have caused this Supplemental Agreement to the Agreement for Professional Services to be executed as of the ____ day of _____ 2009.

THE ENGINEER:
S&B INFRASTRUCTURE, LTD.

BY: _____
Daniel O. Rios, PE, Senior Vice-President
S&B Infrastructure, Ltd.

THE OWNER:
HIDALGO COUNTY DRAINAGE DISTRICT NO. 1

BY: _____
J.D. Salinas, Chairman of the Board

LIST OF ATTACHMENTS
none

Hidalgo County Drainage District No. 1 / S&B Infrastructure, Ltd.
"Master Drainage System Phase II – Raymondville Drain Outfall System "

SUPPLEMENTAL AGREEMENT NO. 3

Page 3 of 3



Project Memorandum

Raymondville Drain Outfall System
Hidalgo County Master Drain System –Phase II



June 30, 2009

TO: Godfrey Garza
District Manager, Hidalgo County Drainage District No. 1

FROM: *Sharlotte L. Teague, PE*
S&B Infrastructure, Ltd. - McAllen

SUBJECT: Supplemental Agreement No. 3

As requested, attached is the final revised SA3 as per Steve's review comments.

As always, if you have any questions, please call at your convenience.
Thanks.

attachments: as identified above

cc: project files – U9444 (HCDD1 correspondence)

AI-16329

7.

**Longhorn Payment Request Request Retainage
DRAINAGE DISTRICT**

Date: 07/14/2009

Submitted By: Minerva Luna, DRAINAGE DISTRICT

Department: DRAINAGE DISTRICT

Information

CAPTION

A. Request approval of Payment Request No. 8 to Longhorn Excavators, Inc. for the Construction of Mission Levee Improvements Project, Inspiration Rd. to Abram Rd. (3.59 miles) Partial release of Retainage.

B. Request approval to process manual checks to Longhorn Excavators, Inc. for the above mentioned project pending completion of the audit process.

BACKGROUND

Fiscal Impact

Attachments

No file(s) attached.

Form Routing/Status

Route Seq	Inbox	Approved By	Date	Status
1	Budget & Management	Erika Zamora	07/09/2009 10:39 AM	APRV
2	Sylvia Solis	Sylvia Solis	07/10/2009 04:52 PM	APRV
3	Final Approval		07/10/2009 05:06 PM	NEW

Form Started By: Minerva Luna

Started On: 07/02/2009 11:08 AM

Final Approval Date: 07/10/2009

AI-16348
DH 0-4A CO#10
DRAINAGE DISTRICT

8.

Date: 07/14/2009
Submitted By: Minerva Luna, DRAINAGE DISTRICT
Department: DRAINAGE DISTRICT

Information

CAPTION

Request approval of Change Order No. 10 on the Contract with Ballenger Construction Company for the Construction of Levee DHS Segment 0-4A. Subject to Department of Homeland Security (DHS) concurrence.

BACKGROUND

Fiscal Impact

Attachments

Link: [DHS 0-4A CO#10](#)

Form Routing/Status

Route Seq	Inbox	Approved By	Date	Status
1	Budget & Management	Erika Zamora	07/06/2009 08:18 AM	APRV
2	Sylvia Solis	Sylvia Solis	07/09/2009 02:03 PM	APRV
3	Final Approval	Angela Garcia	07/10/2009 05:06 PM	APRV

Form Started By: Minerva Luna
Started On: 07/03/2009 10:07 AM

Final Approval Date: 07/10/2009

HIDALGO County Drainage District No. 1
LEVEE IMPROVEMENTS PROJECT
DHS SEGMENT 0-4A (3.91 MILES)

CHANGE ORDER NO. 10

Date: June 22, 2009

Contractor: Ballenger Construction Co.
24200 North FM 509
Harlingen, Texas 78550

Owner: Hidalgo County Drainage District No. 1
902 N. Doolittle Road
Edinburg, Texas 78541

Reference: LEVEE IMPROVEMENTS PROJECT
DHS SEGMENT 0-4A (3.91 MILES)

Contract No. 08-023-09-30
Dannenbaum No. 4287-03

Description: Reduced Retaining Wall Stem quantity.

Contract Amount:

Original Contract Price:	\$	39,809,630.95
Previous Change Order(s):	\$	219,917.88
Contract price prior to this change order:	\$	40,029,548.83
Net increase (decrease) from this change order:	\$	2,660.75
Contract price with all change orders to date (including this change order):	\$	<u>40,032,209.58</u>

Contract Time:

Authorized contract time change:		
Previous Total	0	days
This Change Order	<u>0</u>	days
Total to Date	0	days

APPROVALS:

ENGINEER:
Dannenbaum Engineering Company - McAllen, LLC



Richard D. Seitz, P.E. Date 6/22/09
Resident Project Representative

OWNER:
Hidalgo Co. Drainage Dist. No. 1

JD Salinas Date
Chairman of the Board

ACCEPTED:

CONTRACTOR:
Ballenger Construction Co.

Joe C. Ballenger Date 6/25/09
President

HIDALGO COUNTY
JUL 0 1 2009
DRAINAGE DISTRICT #1

SEGMENT 4A (2" PVC W/ 4" CASSING)

Labor Cost

Name	Hours	Rate	Hrs. X Rate X 1.16 Cost w/Burden	Cost X 0.25 Profit	Cost X 0.55 Burden	Cost + Profit + Burden Total
Foreman	12	\$21.45	\$ 298.58	\$ 74.65	\$ 164.22	\$ 537.45
Backhoe Operator	12	\$8.61	\$ 119.85	\$ 29.96	\$ 65.92	\$ 215.73
Pipe Layer	12	\$8.44	\$ 117.48	\$ 29.37	\$ 64.62	\$ 211.47
Utility Laborer	12	\$9.05	\$ 125.98	\$ 31.49	\$ 69.29	\$ 226.76

Materials

Description	Unit	Qty.	Unit Cost	Unit Cost X Qty. Cost	Cost X 0.25 Profit	Cost + Profit Total Cost
4" PVC Pipe	LF	100	\$ 2.16	\$ 216.00	\$ 54.00	\$ 270.00
4" PVC 45 Degree Bends	EA	4	\$ 9.44	\$ 37.76	\$ 9.44	\$ 47.20
4" PVC Coupling	EA	2	\$ 4.33	\$ 8.66	\$ 2.17	\$ 10.83
PVC Heavy Body Cement Quart	EA	1	\$ 14.15	\$ 14.15	\$ 3.54	\$ 17.69
Purple Primer Quart Can	EA	1	\$ 6.15	\$ 6.15	\$ 1.54	\$ 7.69
2" PVC Pipe	LF	100	\$ 0.87	\$ 87.00	\$ 21.75	\$ 108.75
2" PVC 45 Degree Bends	EA	4	\$ 1.69	\$ 6.76	\$ 1.69	\$ 8.45
2" PVC Coupling	EA	2	\$ 14.16	\$ 28.32	\$ 7.08	\$ 35.40
Wall Penetration (Wall Sleeve)	EA	1	\$ 85.41	\$ 85.41	\$ 21.35	\$ 106.76
Link Seal	EA	6	\$ 5.65	\$ 33.90	\$ 8.48	\$ 42.38

Equipment

Description	Hours	Rate	Rate X Hours Cost	Cost X 0.15 Profit	Cost + Profit Total Cost
Crew Truck	12	\$25.00	\$300.00	\$45.00	\$345.00
Backhoe	12	\$34.00	\$408.00	\$61.20	\$469.20

Labor	\$1,191.41
Materials	\$655.14
Equipment	\$814.20
Grand Total	\$2,660.75

HIDALGO COUNTY
JUL 0 1 2009
DRAINAGE DISTRICT #1

HIDALGO COUNTY DRAINAGE DISTRICT NO. 1
LEVEE IMPROVEMENTS PROJECT

CHANGE ORDER NO. 10

ATTACHMENT B

Date: June 30, 2009

Contractor: Ballenger Construction Co.
24200 North FM 509
Harlingen, Texas 78550

Owner: Hidalgo County Drainage District No. 1
902 N. Doolittle Road
Edinburg, Texas 78541

Reference: LEVEE IMPROVEMENTS
PROJECT
DHS SEGMENT 0-4A (3.91 MI)

Contract No. 08-023-09-30
Dannenbaum No. 4287-03

ENGINEER'S EXPLANATION

DESCRIPTION OF CHANGE

Added new bid item for lowering existing 2 inch waterline.

JUSTIFICATION FOR CHANGE

A previously unknown 2 inch waterline was encountered during construction of the proposed retaining wall. This line is in conflict with the retaining wall construction and required the line to be relocated and sleeved through the wall.

ENGINEER'S JUSTIFICATION OF COST

Contractor was in agreement with Engineer's original "Opinion of Cost" and therefore we recommend execution of this change order for \$2,660.75.

HIDALGO COUNTY

JUL 01 2009

DRAINAGE DISTRICT #1

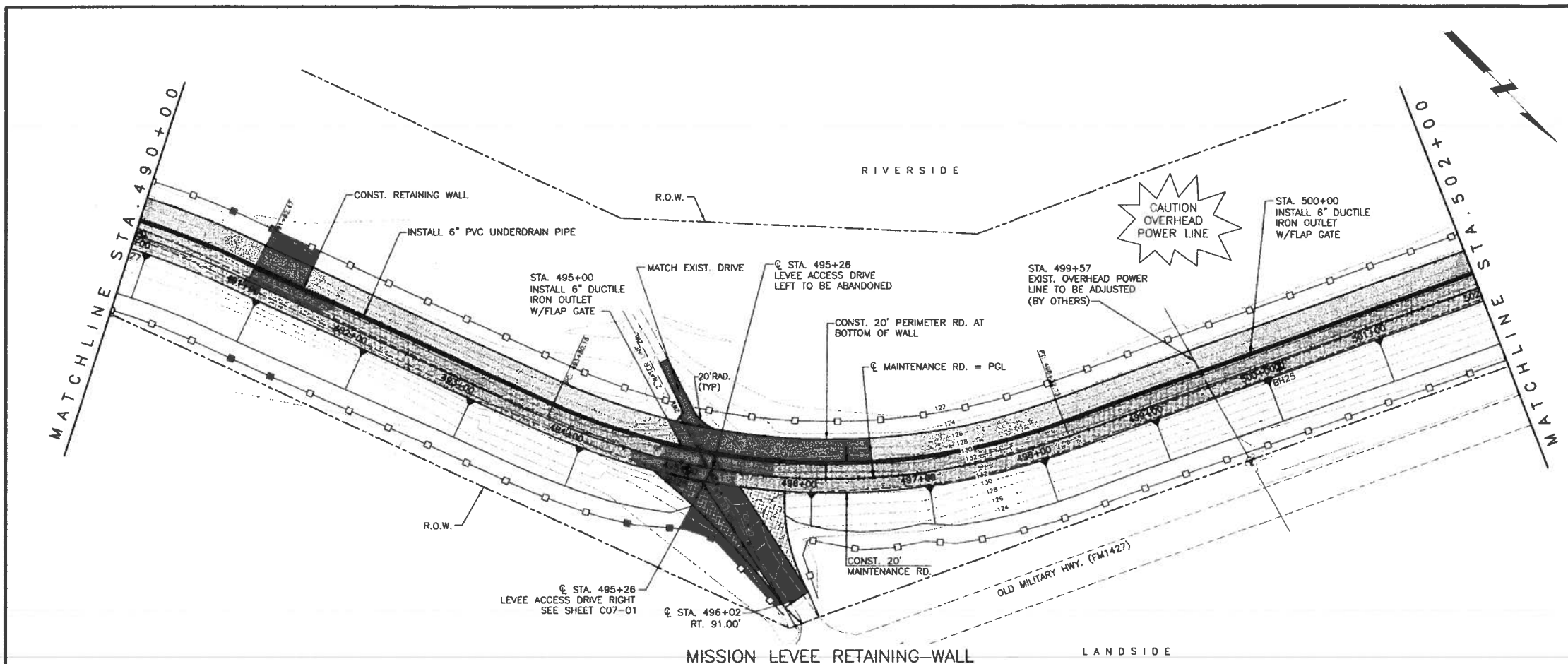

- NOTES:**
- FOR RETAINING WALL DETAILS, SEE "S01" SERIES.
 - FOR MAINTENANCE RD. DETAILS, SEE SHEET ENTITLED: PROPOSED TYPICAL SECTIONS.
 - PROPOSED MAINTENANCE RD. PGL ELEVATIONS ARE FOR TOP OF CALICHE MATERIAL.
 - FOR UNDERDRAIN DETAILS, SEE SHEETS ENTITLED: RETAINING WALL UNDERDRAIN SYSTEM DETAILS.

LEGEND

- PROPOSED RETAINING WALL
- PROPOSED MAINTENANCE ROAD
- PROPOSED PERIMETER ROAD AT BOTTOM OF WALL
- PROPOSED LEVEE ACCESS DRIVE EMBANKMENT
- PROPOSED SEDIMENT CONTROL FENCE
- EXISTING GEOTECHNICAL BORE
- EXISTING MAINTENANCE ROAD
- EXISTING CONTOURS
- EXISTING OVERHEAD POWERLINE
- PROPOSED GATE
- PROPOSED METAL BEAM GUARD FENCE W/POST

Scale: 1" = 50' (H)
1" = 5' (V)

Rev No.	Description	Chk By.	Date
B	ISSUED FOR CONSTRUCTION		09-16-08
A	EXIST. 2" W.L. CROSSING		03-03-09

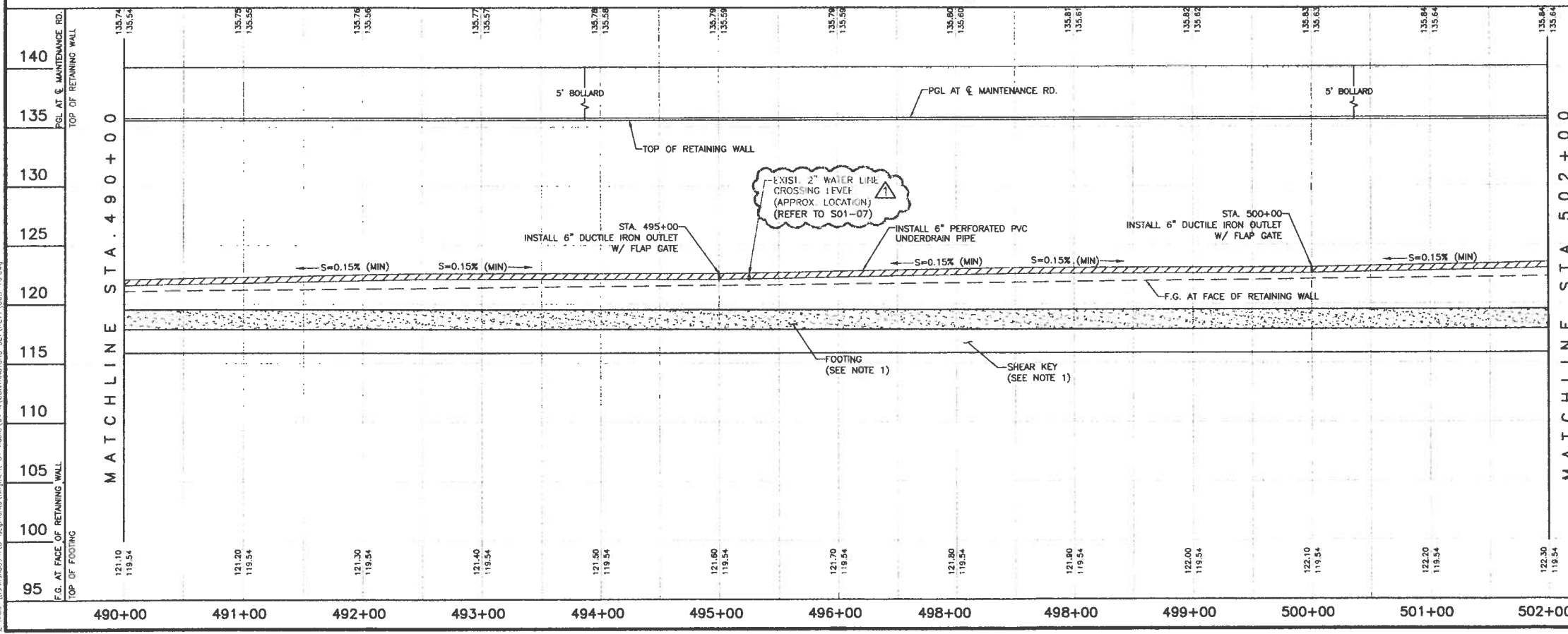

P.G. AT & MAINTENANCE RD. TOP OF RETAINING WALL
 MATCHLINE STA. 490+00
 MATCHLINE STA. 502+00
 F.G. AT FACE OF RETAINING WALL
 TOP OF FOOTING

DANNENBAUM
ENGINEERING COMPANY-McALLEN, LLC
1109 Nolana Loop, Suite 208 McAllen, TX 78504 (956) 682-3677

DL, INC.
DOS LOGISTICS, INC.
212 W. 3rd. Street Phone: (956) 968-8800
Weslaco, Tx. 78596 Fax: (956) 447-8194

MISSION LEVEE
IMPROVEMENT PROJECT
DHS SEGMENT O-4 A

PLAN & PROFILE
STA. 490+00 TO 502+00

SHEET (10 OF 18)

Project No.:	4287-03
Designed By:	H.G.
Drawn By:	E.B., J.M., R.M., J.N.
Checked By:	H.G.
Sheet No.:	C03-10

Hugo P. Gonzalez, Jr.
 Licensed Professional Engineer # 95680

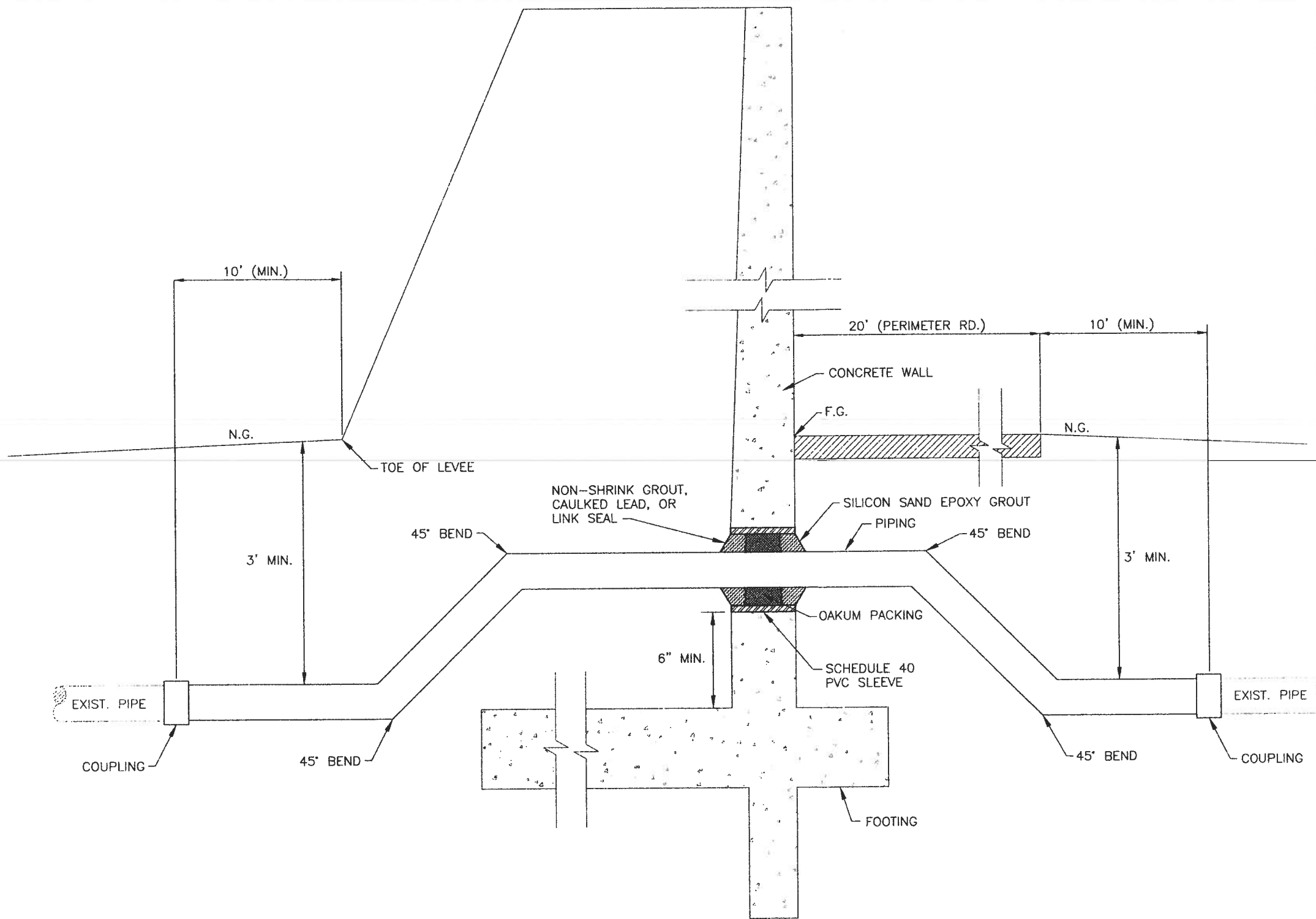

SCALE: N.T.S.

Rev. No.	Description	Chk By:	Date
B	ISSUED FOR CONSTRUCTION		03-03-09
A	WALL PENETRATION DETAIL		03-03-09



DANNENBAUM
ENGINEERING COMPANY-McALLEN, LLC
1109 Nolana Loop, Suite 208 McAllen, TX 78504 (956) 682-3077

DL, INC.
DOS LOGISTICS, INC.
212 W. 3rd Street Phone: (956) 988-8800
Westlaco, Tx. 78596 Fax: (956) 447-8194

MISSION LEVEE
IMPROVEMENT PROJECT
DHS SEGMENT O-4 A

TYPICAL DETAIL OF SLEEVED
CONCRETE WALL PENETRATION
FOR 4" PIPING AND SMALLER

Jose G. Reyes, Jr.
Licensed Professional
Engineer # 93827

Project No.: 4287-03
Designed By: H.G.
Drawn By: E.B., J.M., R.M., J.N.
Checked By: J.R.
Sheet No.: S01-07

Z:\2007\Domenech\0 - Segment\Segment 04 - Rev\04 - A\CONTRACTS SET\RFV\S01-07.dwg

**Rescind Action
DRAINAGE DISTRICT**

Date: 07/14/2009
Submitted By: Jaime Salazar, DRAINAGE DISTRICT
Submitted For: Jaime Salazar
Department: DRAINAGE DISTRICT

Information

CAPTION

- A. Requesting approval to accept bid and award to the most qualified bidder meeting all specified requirements for Bid No. 09-011-06-29 "Auctioneer Services".
- B. Requesting approval to rescind action taken June 30, 2009 (Agenda Item AI-16222 Letter B) "Request approval to reject all bids received for Bid No. 09-010-06-10 Stone Rip Rap and approval to re-advertise."
- C. Requesting approval to modify the Hidalgo County Drainage District No.1 Purchasing Policies and Procedures, pursuant to the State of Texas' 81st Legislative Regular Session, HB 987 effective June 19, 2009. Texas Local Government Code 262 (various causes), 271 (various causes) sealed competitive bid limit is raised from \$25,000.00 to \$50,000.00 and changing from bidding to procurement.

BACKGROUND

Fiscal Impact

Attachments

No file(s) attached.

Form Routing/Status

Route Seq	Inbox	Approved By	Date	Status
1	Budget & Management	Erika Zamora	07/09/2009 08:39 AM	APRV
2	Sylvia Solis	Sylvia Solis	07/10/2009 04:52 PM	APRV
3	Final Approval		07/10/2009 05:06 PM	NEW
Form Started By: Jaime Salazar			Started On: 07/08/2009 02:50 PM	
Final Approval Date: 07/10/2009				

Supp #8 seg 04

DRAINAGE DISTRICT

Date: 07/14/2009

Submitted By: Sylvia Sanchez, DRAINAGE DISTRICT

Submitted For: Sylvia Sanchez

Department: DRAINAGE DISTRICT

Information

CAPTION

A. Request approval of Supplemental Agreement #8 to W/A #6 for the deletion of Supplemental Agreement #5 in relation to Construction Phase services to North Banker Floodway Levee.

B. Request approval of Supplemental Agreement #9 to W/A #6 for Construction Phase services to North Banker Floodway Levee improvement;

C. Request approval of Supplemental Agreement #21 to W/A #3 as it relates to South Option (levee intake crossing) DHS SEg. 04-B.

BACKGROUND

Fiscal Impact

Attachments

Link: [SA #5,8&9 to WA#6](#)

Form Routing/Status

Route Seq	Inbox	Approved By	Date	Status
1	Budget & Management	Erika Zamora	07/09/2009 10:52 AM	APRV
2	Sylvia Solis	Sylvia Solis	07/10/2009 01:12 PM	APRV
3	Final Approval		07/10/2009 05:06 PM	NEW
Form Started By: Sylvia Sanchez			Started On: 07/09/2009 10:14 AM	
Final Approval Date: 07/10/2009				

DANNENBAUM ENGINEERING COMPANY - McALLEN LLC

1109 NOLANA LOOP, SUITE 208 McALLEN, TEXAS 78504 (956) 682-3677

July 8, 2009

COPY

Godfrey Garza
Hidalgo County Drainage District No. 1
902 N. Doolittle
Edinburg, Texas 78541

**Re: Supplemental Agreement No. 5, No. 8 and No. 9 to Work Authorization No. 6
Construction Phase Services for North Banker Floodway Levee (2.9 Miles)**

Dear Mr. Garza,

Dannenbaum Engineering Company – McAllen, LLC and Hidalgo County Drainage District No. 1 currently have an executed Supplemental Agreement No. 5 under Work Authorization No. 6 for construction / inspection phase services for the North Banker Floodway Levee (2.9 miles).

However, in light of the fact USIBWC will be handling the construction of this project and Dannenbaum will be providing assistance to USIBWC through HCDD No.1, we are rescinding Supplemental Agreement No. 5 to Work Authorization No. 6 and resubmitting another supplemental agreement to cover the tasks Dannenbaum will be performing to assist USIBWC thru HCDD No. 1 during construction phase services.

Enclosed please find the following:

- Supplemental Agreement No. 8 – This supplemental agreement rescinds Supplemental Agreement No. 5 (*Reduces the contract by \$50,750.00*)
- Supplemental Agreement No. 9 – This supplemental agreement adds the tasks Dannenbaum will be performing to assist USIBWC thru HCDD No. 1 during construction of the project. (*Increases the contract by \$42,406.19*)

Please review our Supplemental Agreement No. 8 and No. 9, and based on your approval, please sign both copies and return one original to us for our records.

We appreciate the opportunity to be of service to Hidalgo County Drainage District No.1. If you have any questions or need further clarification of this correspondence, please do not hesitate to call me at (956)682-3677 or (832)771-4904.

Sincerely,



Louis H. Jones Jr., P.E.
President

Enclosure(s)

cc: Richard Seitz, P.E.
Omar Anzaldua, P.E.

HIDALGO COUNTY

JUL 08 2009

DRAINAGE DISTRICT #1

Agreement No. 5 regarding bid phase services; construction engineering phase services (shop drawings, change orders, etc.) and engineering inspection services for said project.

NOW THEREFORE, premises considered, the **OWNER** and **ENGINEER** agree that said Agreement is amended as follows:

I. Section of the Agreement, Part 2. Estimated Lump Cost is revised to delete services under Supplemental Agreement No. 5 regarding bid phase services; construction engineering phase services (shop drawings, change orders, etc.) and engineering inspection services under Work Authorization No. 6 for Levee System Improvements – USIBWC North Levee of the USIBWC Floodway from 23rd street to the east end of the USIBWC/ DHS Flood Structure 0-5 (2.9 miles) a total reduction of (\$50,750.00). (See Exhibit “D”)

IN WITNESS WHEREOF, the **ENGINEER** and the **OWNER** have caused this **Supplemental Agreement No. 5** to be effective as of the ____ day of _____, 2009.

ENGINEER:
DANNENBAUM ENGINEERING COMPANY –
MCALLEN, LLC

BY: _____
Louis H. Jones, Jr., P.E., President

OWNER:
HIDALGO COUNTY

BY: _____
J.D. Salinas, County Judge

ATTACHMENTS:

Exhibit D – Deletion of Services under Supplemental Agreement No. 5 regarding bid phase services; construction engineering phase services (shop drawings, change orders, etc.) and engineering inspection services for said project.

Hidalgo County Drainage District No. 1 / Dannenbaum Engineering Company – McAllen, LLC
Supplemental Agreement No. 8 to WA No. 6 – USIBWC North Levee of the USIBWC Floodway (2.9 Miles)
HIDALGO COUNTY “Levee System Improvements within Hidalgo County, Texas”

JUL 08 2009

DRAINAGE DISTRICT #1

EXHIBIT “F”
Page 2 of 2

DANNENBAUM ENGINEERING COMPANY - McALLEN LLC

1109 NOLANA LOOP, SUITE 208 McALLEN, TEXAS 78504 (956) 682-3677

July 8, 2009

COPY

Godfrey Garza
Hidalgo County Drainage District No. 1
902 N. Doolittle
Edinburg, Texas 78541

**Re: Supplemental Agreement No. 5, No. 8 and No. 9 to Work Authorization No. 6
Construction Phase Services for North Banker Floodway Levee (2.9 Miles)**

Dear Mr. Garza,

Dannenbaum Engineering Company – McAllen, LLC and Hidalgo County Drainage District No. 1 currently have an executed Supplemental Agreement No. 5 under Work Authorization No. 6 for construction / inspection phase services for the North Banker Floodway Levee (2.9 miles).

However, in light of the fact USIBWC will be handling the construction of this project and Dannenbaum will be providing assistance to USIBWC through HCDD No.1, we are rescinding Supplemental Agreement No. 5 to Work Authorization No. 6 and resubmitting another supplemental agreement to cover the tasks Dannenbaum will be performing to assist USIBWC thru HCDD No. 1 during construction phase services.

Enclosed please find the following:

- Supplemental Agreement No. 8 – This supplemental agreement rescinds Supplemental Agreement No. 5 (*Reduces the contract by \$50,750.00*)
- Supplemental Agreement No. 9 – This supplemental agreement adds the tasks Dannenbaum will be performing to assist USIBWC thru HCDD No. 1 during construction of the project. (*Increases the contract by \$42,406.19*)

Please review our Supplemental Agreement No. 8 and No. 9, and based on your approval, please sign both copies and return one original to us for our records.

We appreciate the opportunity to be of service to Hidalgo County Drainage District No.1. If you have any questions or need further clarification of this correspondence, please do not hesitate to call me at (956)682-3677 or (832)771-4904.

Sincerely,

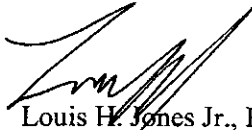

Louis H. Jones Jr., P.E.
President

Enclosure(s)

cc: Richard Seitz, P.E.
Omar Anzaldua, P.E.

HIDALGO COUNTY

JUL 08 2009

DRAINAGE DISTRICT #1

NOW THEREFORE, premises considered, the OWNER and ENGINEER agree that said Agreement is amended as follows:

I. Section of the Agreement, Part 2. Estimated Lump Cost is revised to provide bid phase services; construction engineering phase services (shop drawings, change orders, etc.) and engineering inspection services under **Work Authorization No. 6 (Levee System Improvements – USIBWC North Levee of the USIBWC Floodway from 23rd street to the east end of the USIBWC/DHS Flood Structure 0-5 (2.9 miles) for a lump sum cost of \$42,406.19.** (See Exhibit “D”)

IN WITNESS WHEREOF, the ENGINEER and the OWNER have caused this Supplemental Agreement No. 9 to be effective as of the ___ day of _____, 2009.

ENGINEER:
DANNENBAUM ENGINEERING COMPANY –
MCALLEN, LLC

BY: 
Louis H. Jones, Jr., P.E., President

OWNER:
HIDALGO COUNTY

BY: _____
J.D. Salinas, County Judge

ATTACHMENTS:

Exhibit D – Lump Sum Fee Budget Estimate for bid phase services; construction engineering phase services (shop drawings, change orders, etc.) and engineering inspection services for said project.

Hidalgo County Drainage District No. 1 / Dannenbaum Engineering Company – McAllen, LLC
Supplemental Agreement No. 9 to WA No. 6 – USIBWC North Levee of the USIBWC Floodway (2.9 Miles)
“Levee System Improvements within Hidalgo County, Texas”

HIDALGO COUNTY

JUL 06 2009

DRAINAGE DISTRICT #1

EXHIBIT “F”
Page 2 of 2

DANNENBAUM ENGINEERING COMPANY - McALLEN LLC

1109 NOLANA LOOP, SUITE 208 McALLEN, TEXAS 78504 (956) 682-3677

July 7, 2009

COPY

Mr. Godfrey Garza
Hidalgo County Drainage District No. 1
902 North Doolittle Road
Edinburg, Texas 78541

RE: Hidalgo County Levee Improvement Project

SUBJ: DHS Segment O-4B (Revised 06/02/09) (South Option – Levee Intake Crossing)

Dear Mr. Garza,

Dannenbaum is in receipt of e-mail correspondence received from your office dated July 2, 2009 requesting the revised construction cost of DHS Segment O-4B. (See the attached.)

Enclosed please find the revised construction cost based on comments received from DHS and USIBWC at the weekly DHS conference call of July 1, 2009. Revisions to the construction cost include the following:

- Stone Rip Rap was changed to Concrete Rip Rap
- Caliche perimeter road connecting to 04C was added
- 36" RCP was extended and a section of ditch was covered
- Additional 10' of bollards welded to provide tactical height (04A end)

Dannenbaum is submitting a supplemental agreement based on this construction cost under separate cover for your review and approval. As stated in previous correspondence, Dannenbaum and our subconsultant, DOS Logistics, have been providing engineering services in the spirit of good faith to complete the final design of DHS Segment O-4B (South Option – Levee Intake Crossing) to expedite the construction of this project. Currently, the final design of this project is approximately 100% complete.

If you have any questions or need clarification of this correspondence, please do not hesitate to call me at (956)682-3677.

Sincerely,

Louis H. Jones, P.E.
President

Enclosures

cc: Richard D. Seitz, P.E., Dannenbaum
Omar Anzaldua, P.E., Dannenbaum
Hugo Gonzales, P.E., Dos Logistics

HIDALGO COUNTY
JUL 07 2009
DRAINAGE DISTRICT #1

Sandra Spence

From: lora.briones [lora.briones@hcdd1.org]
Sent: Thursday, July 02, 2009 12:00 PM
To: Sandra Spence
Cc: Richard Seitz; Louis Jones; g.g@hcdd1.org; 'Minerva Luna'
Subject: Engineering Estimate on DHS Segment 4B

Sandra,

Please prepare and submit engineering estimate on DHS Segment 4B so negotiation may begin. Thank you.

Lora Briones
Hidalgo County Drainage District #1
902 North Doolittle
Edinburg, Texas 78541
Off: (956) 292-7080 ext 5803
Fax: (956) 292-7089
lora.briones@hcdd1.org

HIDALGO COUNTY

JUL 07 2009

DRAINAGE DISTRICT #1

THE STATE OF TEXAS §
 §
COUNTY OF HIDALGO §

EXHIBIT "F"
Supplemental Agreement Form

SUPPLEMENTAL AGREEMENT NO. 21 (Revised 07/07/09)
TO WORK AUTHORIZATION NO. 3
TO AGREEMENT FOR PROFESSIONAL SERVICES

THIS SUPPLEMENTAL AGREEMENT is made pursuant to the terms and conditions of Section 4 of the Agreement made by and between the **HIDALGO COUNTY DRAINAGE DISTRICT NO. 1**, acting herein by and through its **BOARD OF DIRECTORS**, hereinafter called the **OWNER** and **DANNENBAUM ENGINEERING COMPANY – MCALLEN, LLC**, professional engineers of McAllen, Texas, hereinafter called the **ENGINEER**.

WITNESSETH

WHEREAS, the **OWNER** and the **ENGINEER** executed the Main Contract Agreement on the 7th day November, 2006 concerning engineering and related services of the facilities for the "Levee System Improvements within Hidalgo County, Texas" (hereinafter referred to as the "Project"); and executed Work Authorization No. 3 under said agreement on the 3rd day of July, 2007; and,

WHEREAS, Section Part 1 of Work Authorization No. 3, Scope of Work, establishes the scope of work for the Hidalgo County Drainage District No. 1 proposed levee improvement projects, and,

WHEREAS, it has become necessary to amend "Exhibit B" of Work Authorization No. 3 (Levee System Improvements for Department of Homeland Security Levee/Wall Segment O-4, which includes Segments O-4A (3.91 Miles); O-4C (0.44 Miles); and now O-4B Fence Extension - South Option (Levee Intake Crossing) for the development of preliminary engineering, final design and bid / construction administration phase services for Segment O-4B Fence Extension South Option (Levee Intake Crossing) as outlined in Exhibit "D" to this supplemental agreement.

HIDALGO COUNTY

JUL 07 2009

DRAINAGE DISTRICT #1

*Hidalgo County Drainage District No. 1 / Dannenbaum Engineering Company – McAllen, LLC
SA No. 21 to WA No.3 / DHS Levee/Wall Segments O-4B South Option (Levee Intake Crossing)
"Levee System Improvements within Hidalgo County, Texas"*

EXHIBIT "F"

Page 1 of 2

NOW THEREFORE, premises considered, the **OWNER** and **ENGINEER** agree that said Agreement is amended as follows:

I. Section of the Agreement, Part 2. Estimated Cost is revised to provide preliminary engineering, final design and bid / construction administration phase services for Segment O-4B Fence Extension South Option (Levee Intake Crossing) under Work Authorization No. 3 for a lump sum total of \$336,954.38.

IN WITNESS WHEREOF, the **ENGINEER** and the **OWNER** have caused this **Supplemental Agreement No. 21 (Revised 07/07/09)** to be effective as of the ____ day of _____, 2009.

ENGINEER:
DANNENBAUM ENGINEERING COMPANY –
MCALLEN, LLC

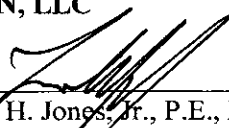
BY: 
Louis H. Jones, Jr., P.E., President

OWNER:
HIDALGO COUNTY

BY: _____
J.D. Salinas, County Judge

ATTACHMENTS:
Exhibit "D" – Lump Sum Fee Budget Estimate for DHS Seg O-4B South Option (Levee Intake Crossing)

HIDALGO COUNTY

JUL 07 2009

DRAINAGE DISTRICT #1

*Hidalgo County Drainage District No. 1 / Dannenbaum Engineering Company – McAllen, LLC
SA No. 21 to WA No.3 / DHS Levee/Wall Segments O-4B South Option (Levee Intake Crossing)
"Levee System Improvements within Hidalgo County, Texas"*

EXHIBIT "F"

Page 2 of 2

**DHS 0-6A, 0-9 PH I and DHS 0-10 Change Orders
DRAINAGE DISTRICT**

Date: 07/14/2009
Submitted By: Minerva Luna, DRAINAGE DISTRICT
Department: DRAINAGE DISTRICT

Information

CAPTION

- A. Request approval of Change Order No. 19 on the Contract with Ballenger Construction Company for the Construction of Levee DHS Segment 0-6A. Subject to Department of Homeland Security (DHS) concurrence.
- B. Request approval of Change Order No. 13 on the Contract with Williams Brothers Construction Company, Inc. for the Construction of Levee DHS Segment 0-9 PH I. Subject to Department of Homeland Security (DHS) concurrence.
- C. Request approval of Change Order No. 13 on the Contract with Williams Brothers Construction Company, Inc. for the Construction of Levee DHS Segment 0-10. Subject to Department of Homeland Security (DHS) concurrence.

BACKGROUND

Fiscal Impact

Attachments

- Link: [DHS 0-6A CO#19](#)
- Link: [DHS 0-9 PH I CO#13](#)
- Link: [DHS 0-10 CO#13](#)

Form Routing/Status

Route Seq	Inbox	Approved By	Date	Status
1	Budget & Management	Erika Zamora	07/10/2009 10:06 AM	APRV
2	Sylvia Solis	Sylvia Solis	07/10/2009 01:19 PM	APRV
3	Final Approval		07/10/2009 05:06 PM	NEW

Form Started By: Minerva Luna

Started On: 07/10/2009 09:09 AM

Final Approval Date: 07/10/2009

HIDALGO County Drainage District No. 1
LEVEE IMPROVEMENTS PROJECT
DHS SEGMENT 0-6A (2.59 MILES)

CHANGE ORDER NO. 19

Date: June 22, 2009

Contractor: Ballenger Construction Co.
24200 North FM 509
Harlingen, Texas 78550

Owner: Hidalgo County Drainage District No. 1
902 N. Doolittle Road
Edinburg, Texas 78541

Reference: LEVEE IMPROVEMENTS PROJECT
DHS SEGMENT 0-6A (2.59 MILES)

Contract No. 08-016-09-02
Dannenbaum No. 4410-07

Description:

Revised quantities associated with Structure 326L.

Contract Amount:

Original Contract Price:	\$	28,553,870.93
Previous Change Order(s):	\$	(2,822,379.70)
Contract price prior to this change order:	\$	25,731,491.23
Net increase (decrease) from this change order:	\$	6,115.25
Contract price with all change orders to date (including this change order):	\$	<u>25,737,606.48</u>

APPROVALS:

ENGINEER:

Dannenbaum Engineering Company - McAllen, LLC

Richard D. Seitz, P.E.
Resident Project Representative

Date

6/22/09

OWNER:

Hidalgo Co. Drainage Dist. No. 1

JD Salinas
Chairman of the Board

Date

ACCEPTED:

CONTRACTOR:

Ballenger Construction Co.

Joe C. Ballenger, Jr.
President

Date

6/24/09

HIDALGO COUNTY

JUL 07 2009

DRAINAGE DISTRICT #1

HIDALGO County Drainage District No. 1
 LEVEE IMPROVEMENTS PROJECT
 DHS SEGMENT 0-6A (2.59 MILES)

CHANGE ORDER NO. 19

ATTACHMENT A

TABULATION OF QUANTITY AND COST

Date: June 22, 2009 Contract No. 08-016-09-02
 Contractor: Balleger Construction Co. Dannenbaum No.
24200 North FM 509 4410-07
Harlingen, Texas 78550

Description: Revised quantities associated with Structure 326L.

COST SUMMARY

BID ITEM NO.	UNITS	PREVIOUS QNTYS		REVISED QNTYS		VARIANCE AMOUNT
		QNTYS	UNIT PRICE	QNTYS	UNIT PRICE	
6	EA	2.00	\$1,311.48	0.00	\$ 1,311.48	\$ (2,622.96)
7	EA	2.00	\$1,646.24	5.00	\$ 1,646.24	\$ 8,231.20
12	CY	1,355.00	\$1,373.83	1,354.39	\$ 1,373.83	\$ (838.04)
20	EA	2.00	\$1,680.40	0.00	\$ 1,680.40	\$ (3,360.80)
21	EA	1.12	\$3,360.79	2.12	\$ 3,360.79	\$ 3,360.79
42	LF	56.00	\$298.83	0.00	\$ 258.83	\$ (14,494.48)
43	LF	71.00	\$289.80	127.00	\$ 289.80	\$ 16,228.80
67	CY	0.00	\$ -	9.00	\$ 322.58	\$ 2,903.22
GRAND TOTAL						\$ 6,115.25

HIDALGO COUNTY

JUL 07 2009

DRAINAGE DISTRICT #1

HIDALGO County Drainage District No. 1
 LEVEE IMPROVEMENTS PROJECT
 DHS SEGMENT 0-6A (2.59 MILES)

CHANGE ORDER NO. 19

ATTACHMENT B

ENGINEER'S PRELIMINARY OPINION OF COST

Date: June 22, 2009

Contractor: Ballenger Construction Co.

24200 North FM 509

Harlingen, Texas 78550

Contract No.
 Dannenbaum No.

08-016-09-02

4410-07

Description:

Revised quantities associated with Structure 326L.

COST SUMMARY

BID ITEM NO.	UNITS	PREVIOUS QNTYS		REVISED QNTYS		VARIANCE AMOUNT
		QNTYS	UNIT PRICE	QNTYS	UNIT PRICE	
6	EA	2.00	\$1,311.48	0.00	\$ 1,311.48	\$ -
						\$ (2,622.96)
7	EA	2.00	\$1,646.24	5.00	\$ 1,646.24	\$ 8,231.20
						\$ 4,938.72
12	CY	1,355.00	\$1,373.83	1,354.39	\$ 1,373.83	\$ 1,860,701.61
						\$ (838.04)
20	EA	2.00	\$1,680.40	0.00	\$ 1,680.40	\$ -
						\$ (3,360.80)
21	EA	1.12	\$3,360.79	2.12	\$ 3,360.79	\$ 7,124.87
						\$ 3,360.79
42	LF	56.00	\$258.83	0.00	\$ 258.83	\$ -
						\$ (14,494.48)
43	LF	71.00	\$289.80	127.00	\$ 289.80	\$ 36,804.60
						\$ 16,228.80
67	CY	0.00	\$ -	9.00	\$ 322.58	\$ 2,903.22
						\$ 2,903.22
GRAND TOTAL						\$ 6,115.25

HIDALGO COUNTY

JUL 07 2009

DRAINAGE DISTRICT #1

HIDALGO COUNTY DRAINAGE DISTRICT NO. 1
LEVEE IMPROVEMENTS PROJECT

CHANGE ORDER NO. 19

ATTACHMENT B

Date: June 30, 2009

Contractor: BALENGER CONSTRUCTION
CO.
24200 North FM 509
Harlingen, Texas 78550

Owner: Hidalgo County Drainage District No. 1
902 N. Doolittle Road
Edinburg, Texas 78541

Reference: LEVEE IMPROVEMENTS
PROJECT
DHS SEGMENT 0-6A (2.59 MI)

Contract No. 08-016-09-02

Dannenbaum No. 4410-07

ENGINEER'S EXPLANATION

DESCRIPTION OF CHANGE

Revised quantities associated with Structure 326L.

JUSTIFICATION FOR CHANGE

An existing 54" concrete pipe at Station 96+85 was originally going to pass under our proposed retaining wall key. However, during construction it was discovered that the elevation of this existing pipe was higher than previously anticipated. As a result, we were forced to revise our retaining wall details in order allow this 54" concrete pipe to pass through our key rather than under.

ENGINEER'S JUSTIFICATION OF COST

Contractor was in agreement with Engineer's original "Opinion of Cost" and therefore we recommend execution of this change order for \$6,115.25.

HIDALGO COUNTY

JUL 07 2009

DRAINAGE DISTRICT #1

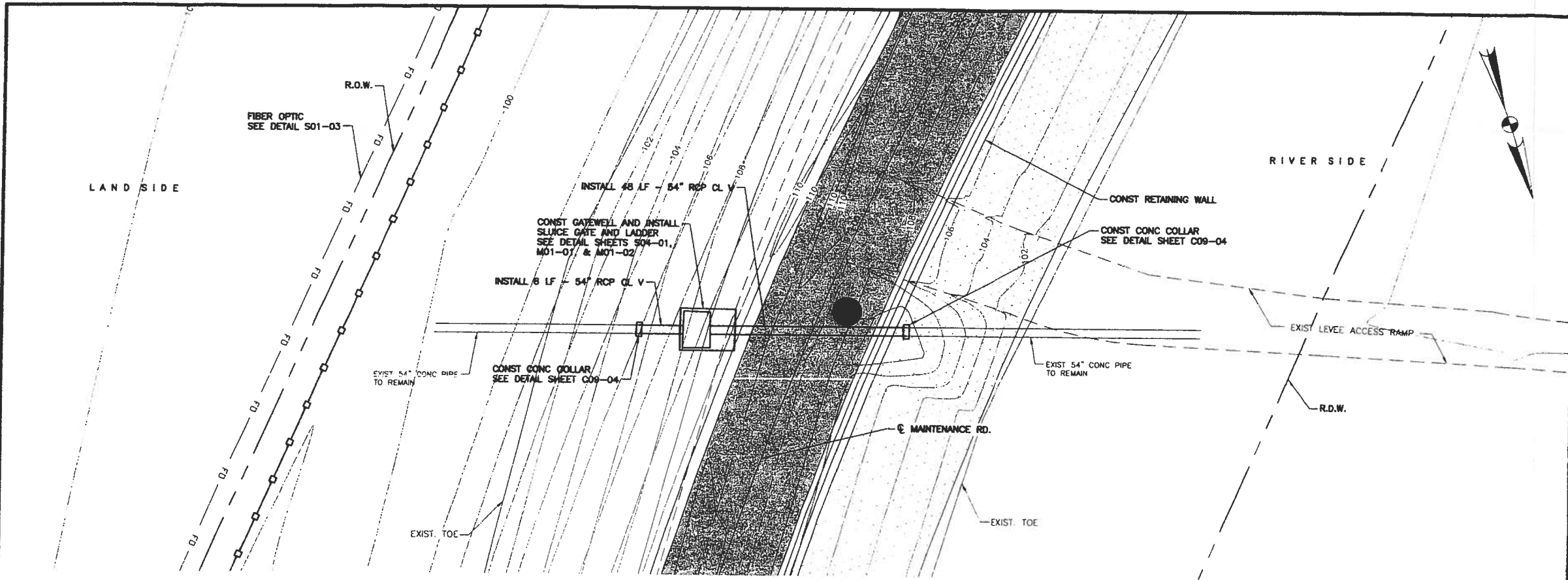

PLAN
RELOCATED STRUCTURE No. 326L
SCALE: 1"=10'

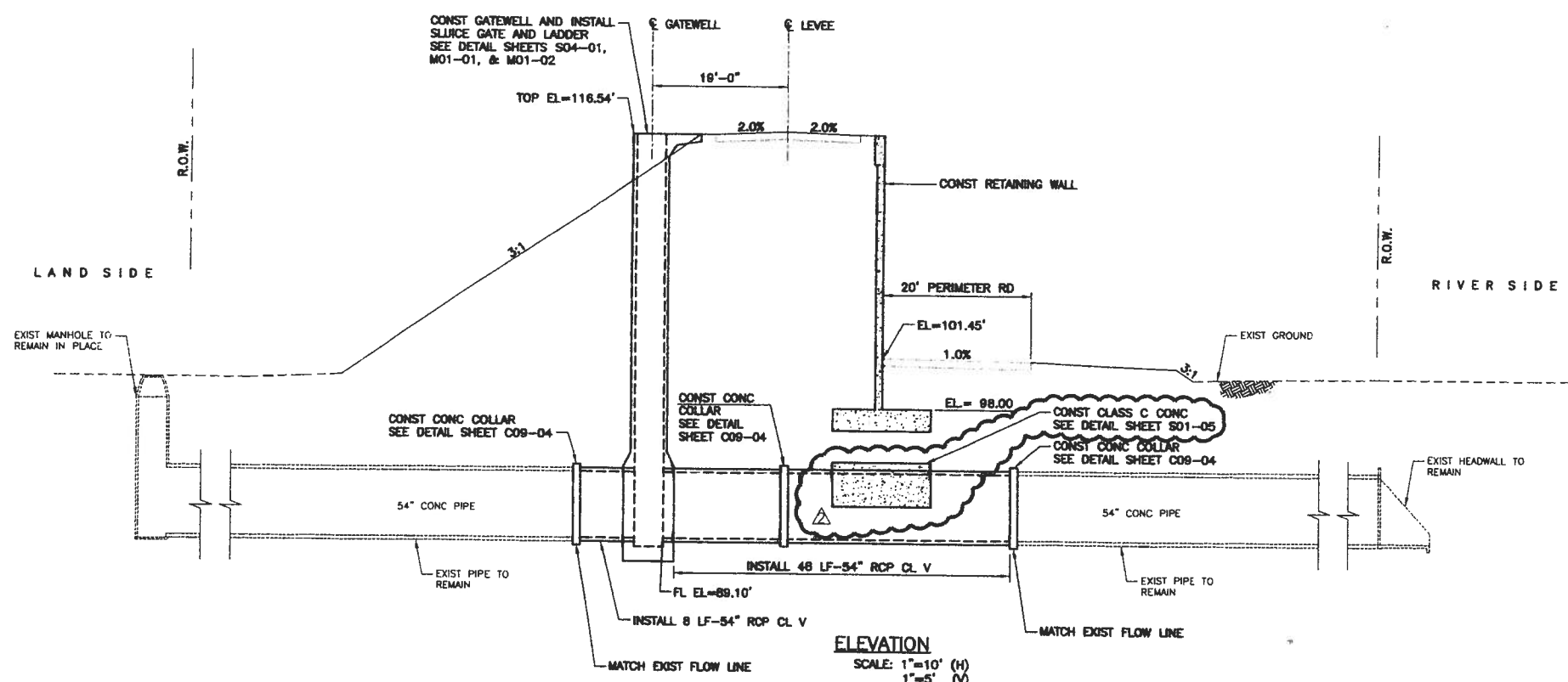

ELEVATION
SCALE: 1"=10' (H)
1"=5' (V)

- NOTES:**
1. SEE "C02" SERIES SHEETS FOR TYPICAL SECTIONS.
 2. SEE "S01" SERIES SHEETS FOR RETAINING WALL DETAILS.
 3. SEE "C10" SERIES SHEETS FOR RETAINING WALL UNDERDRAIN SYSTEM DETAILS.
 4. SEE "C08" SERIES SHEETS FOR ACCESS RAMP DETAILS.
 5. SEE "S02" SERIES SHEETS FOR BOLLARD DETAILS.
 6. WATER STRIKE SHOWN ON PROFILE WAS DEVELOPED BY CONNECTING WATER STRIKE ELEVATIONS SHOWN IN GEOTECHNICAL REPORT FOR THIS PROJECT AND IS PROVIDED FOR CONTRACTOR INFORMATION ONLY.

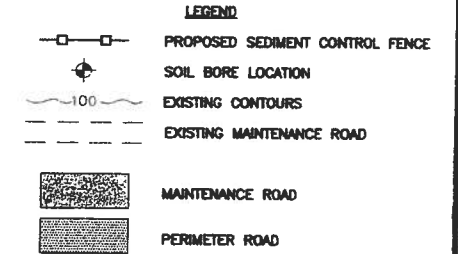

Rev. No	Description	Chk. By:	Date
IFC	ISSUED FOR CONSTRUCTION	R.S.	11-03-08
Δ	REVISED PIPE SIZES	R.S.	03-18-09
Δ	REVISED CONC. COLLAR	R.S.	05-08-09



DANNENBAUM
ENGINEERING COMPANY-McALLEN, LLC
1109 Nolana Loop, Suite 208 McAllen, TX 78504 (956) 682-3677
Registration No. 6999

HIDALGO PROTECTIVE LEVEE
IMPROVEMENT PROJECT
DHS PF 225: O-6 A

STA 96+85
REMOVE AND REPLACE EXISTING
STRUCTURE No. 326L
(2 OF 2)

SHEET (6 OF 10)

Project No.: 4410-07

Designed By: O.A.

Drawn By: H.R.V.

Checked By: R.S.

SHEET No.: C06-06

Date: 5-8-09

Omar Anzures, Jr., P.E.

C:\1540\287-14\Levee 0-6\Levee 0-6\Revision 1\Proposed Structure 326L_R02.dwg
 User: O.A. Date: 5/8/09 2:46pm Plotter: HP DesignJet 5000PS

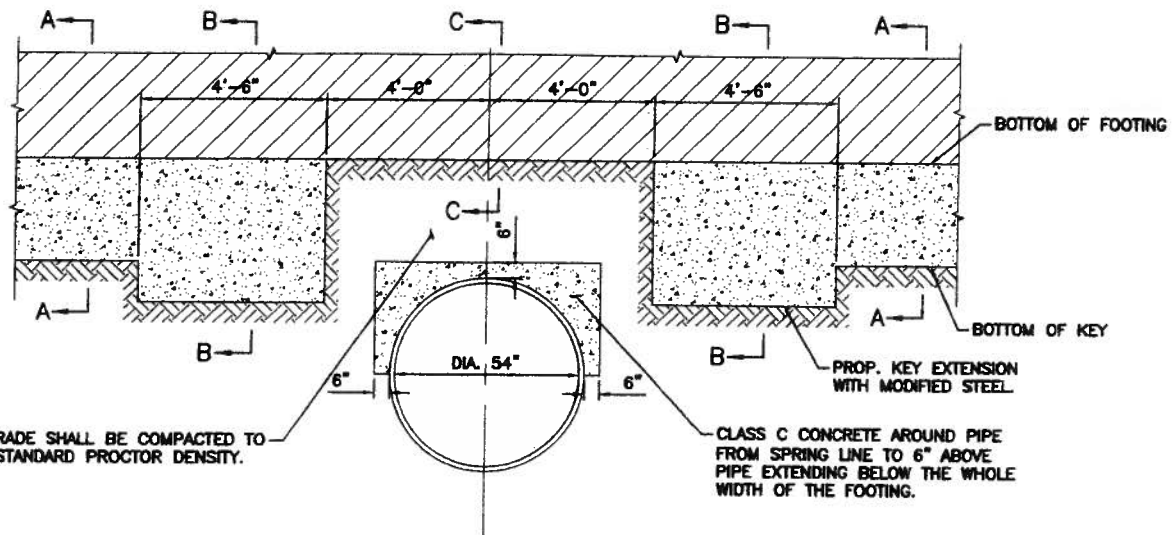

SUBGRADE SHALL BE COMPACTED TO 95% STANDARD PROCTOR DENSITY.

CLASS C CONCRETE AROUND PIPE FROM SPRING LINE TO 6" ABOVE PIPE EXTENDING BELOW THE WHOLE WIDTH OF THE FOOTING.

NOTE:
ONLY REINFORCING BARS RELATED TO SHEAR KEY ARE SHOWN FOR CLARITY.

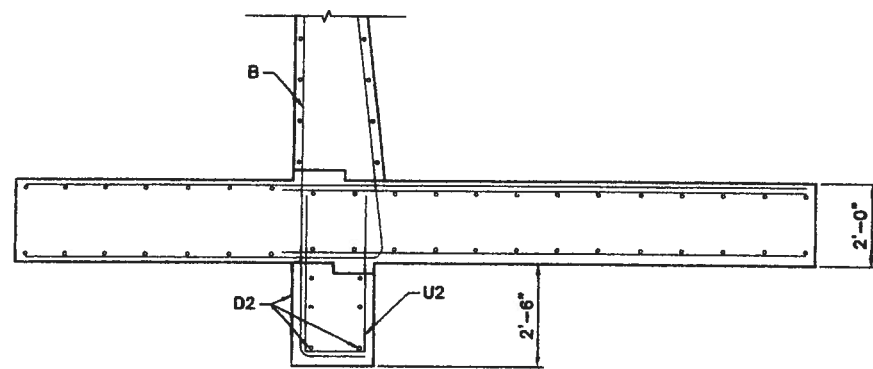

SECTION A-A
SCALE: 1/2"=1'

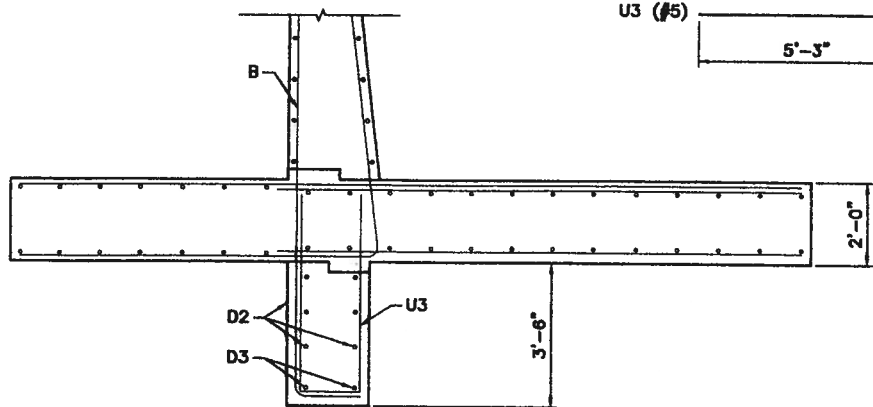
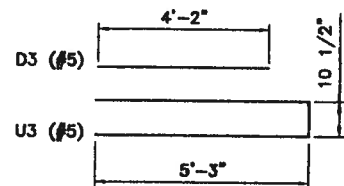

SECTION B-B
SCALE: 1/2"=1'

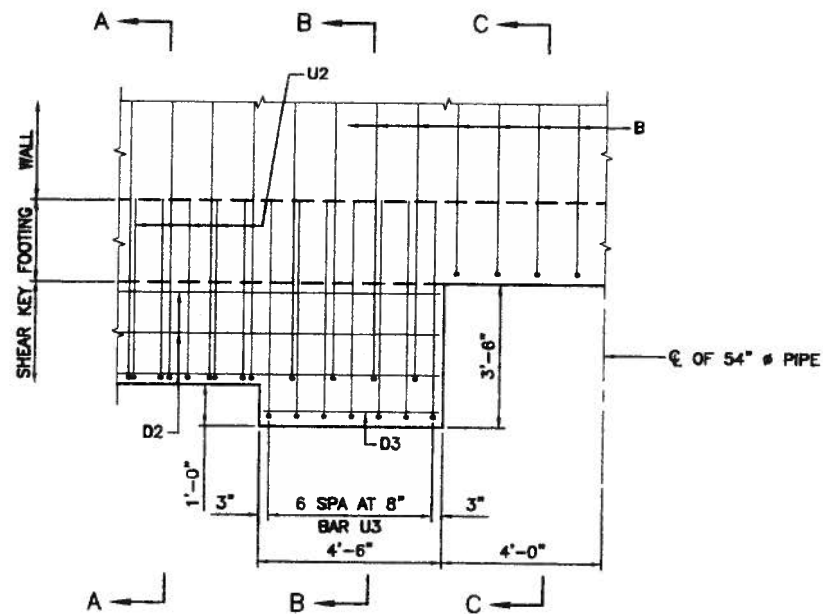

REINFORCING BAR DETAIL
SCALE: 1/2"=1'

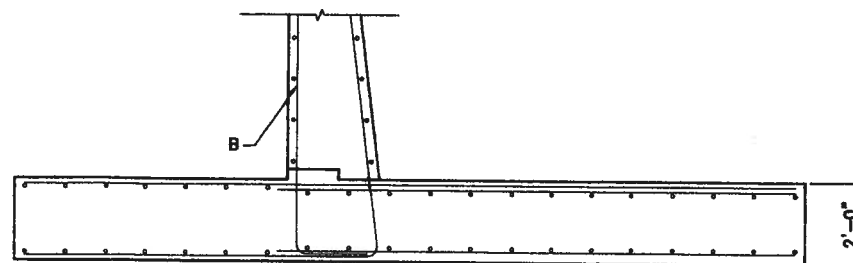

SECTION C-C
SCALE: 1/2"=1'

- NOTES:
1. REFER TO S01-01B FOR GENERAL NOTES.
2. CONCRETE COLLAR SHALL BE CONSTRUCTED AROUND PIPE AS SHOWN ON DETAIL SHEET C09-04 TO PREVENT WATER PENETRATION.

Rev. No.	Description	Chk. By:	Date
IFC	ISSUED FOR CONSTRUCTION	R.S.	03-23-09



DANNENBAUM

ENGINEERING COMPANY-McALLEN, LLC
1109 Nolans Loop, Suite 208 McAllen, TX 78504 (956) 682-3677
Registration No. 6999

HIDALGO PROTECTIVE LEVEE
IMPROVEMENT PROJECT
DHS PF 225: O-6 A

STRUCTURE 326L
54" PIPE CROSSING
STA. 06+85
DETAIL

SHEET (1 OF 1)

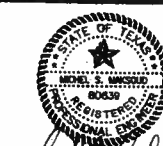

Michel S. Marsood, P.E.
Date: 4-1-09

Project No.:	4410-07
Designed By:	W.P.C.
Drawn By:	H.R.
Checked By:	O.A.J.
Sheet No.:	S01-05

**HIDALGO County Drainage District No. 1
LEVEE IMPROVEMENTS PROJECT
DHS SEGMENT 0-9 PHASE I (2.12 MILES)**

CHANGE ORDER NO. 13

Date: June 15, 2009

Contractor: WILLIAMS BROTHERS CONSTRUCTION CO., INC.
3800 Milam
Houston, Tx 77006

Owner: Hidalgo County Drainage District No. 1
902 N. Doolittle Road
Edinburg, Texas 78541

Reference: LEVEE IMPROVEMENTS PROJECT
DHS SEGMENT 0-9 PHASE I (2.12 MILES)

Contract No. 08-013-07-08
Dannenbaum No. 4410-04

Description:
Revised Final Completion date from April 1, 2009 to May 16, 2009.

Contract Amount:

Original Contract Price:	\$ 20,253,897.40
Previous Change Order(s):	\$ (2,685,398.06)
Contract price prior to this change order:	\$ 17,568,499.34
Net increase (decrease) from this change order:	\$ -
Contract price with all change orders to date (including this change order):	<u>\$ 17,568,499.34</u>

Contract Time:

Authorized contract time change:	
Previous Total	2 days
This Change Order	45 days
Total to Date	<u>47 days</u>

	Substantial Completion	Final Completion
Original Contract Date	12/1/2008	3/30/2009
Revised Contract Date - Previous Change Order	12/3/2008	4/1/2009
Revised Contract Date - This Change Order	N/A	5/16/2009

APPROVALS:

ENGINEER:

Dannenbaum Engineering Company - McAllen, LLC

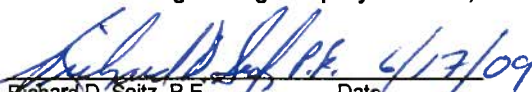
Richard D. Seitz, P.E. Date
Resident Project Representative

OWNER:

Hidalgo Co. Drainage Dist. No. 1

JD Salinas Date
Chairman of the Board

ACCEPTED:

CONTRACTOR:

WILLIAMS BROTHERS CONSTRUCTION CO., INC.

Randy T. Rogers Date
Vice-President

HIDALGO COUNTY

JUL 02 2009

DRAINAGE DISTRICT #1

HIDALGO COUNTY DRAINAGE DISTRICT NO. 1
LEVEE IMPROVEMENTS PROJECT

CHANGE ORDER NO. 13

ATTACHMENT B

Date: July 2, 2009

Contractor: WILLIAMS BROTHERS
CONSTRUCTION CO., INC.
3800 Milam
Houston, Texas 77006

Owner: Hidalgo County Drainage District No. 1
902 N. Doolittle Road
Edinburg, Texas 78541

Reference: LEVEE IMPROVEMENTS
PROJECT
DHS SEGMENT 0-9 PH I (2.12 MI)

Contract No. 08-013-07-08
Dannenbaum No. 4410-04

ENGINEER'S EXPLANATION

DESCRIPTION OF CHANGE

Revised Final Completion date from April 1, 2009 to May 16, 2009.

JUSTIFICATION FOR CHANGE

Additional time required for processing of final project closeout documentation.

ENGINEER'S JUSTIFICATION OF COST

N/A

HIDALGO COUNTY

JUL 02 2009

DRAINAGE DISTRICT #1

PF225 Change Request O-4 thru O-10)

Change Request Number: 108
USBP Sector: RGV

Change Request Date: 6 May 2009
Project/Map ID: O-9 Phase 1

SBI Project Manager: Scott Recinos

USBP Sector TI Coordinator: SBPA Rene Zamora

Change Requested By

Name: Scott Recinos
E-mail Address: Scott.Recinos@cbp.dhs.gov

Telephone Number: 202-344-3215
Fax Number: 202-344-1250

Description of Requested Change:

Levee/Wall DHS Segment O-9 Phase 1 – Change Order No. 13
Revise final completion date from April 1 to May 16, 2009.

Justification for Change:

Final close out of project delayed due to issues beyond the control of the contractor.

Cost Adjustment:

ROM \$0

Schedule Adjustment:

45 days

Notes:

1. SBI TI has reviewed the documentation provided by Hidalgo and believes approving this change request is in CBP's best interest and the best interest of the project.

Approval Signature:



Loren Flossman, Program Manager
Facilities Management & Engineering

15 MAY 09
Date

HIDALGO COUNTY

JUL 02 2009

DRAINAGE DISTRICT #1

**HIDALGO County Drainage District No. 1
LEVEE IMPROVEMENTS PROJECT
DHS SEGMENT 0-10 (2.34 MILES)**

CHANGE ORDER NO. 13

Date: June 15, 2009

Contractor: Williams Brothers Construction Co., Inc.
3800 Milam
Houston, Texas 77006

Owner: Hidalgo County Drainage District No. 1
902 N. Doolittle Road
Edinburg, Texas 78541

Reference: LEVEE IMPROVEMENTS PROJECT
DHS SEGMENT 0-10 (2.34 MILES)

Contract No. 08-014-07-08
Dannenbaum No. 4410-05

Description:
Revised Final Completion date from March 30, 2009 to May 16, 2009.

Contract Amount:

Original Contract Price:	\$ 18,763,215.00
Previous Change Order(s):	\$ 321,729.70
Contract price prior to this change order:	\$ 19,084,944.70
Net increase (decrease) from this change order:	\$ -
Contract price with all change orders to date (including this change order):	\$ 19,084,944.70

Contract Time:

Authorized contract time change:	
Previous Total	0 days
This Change Order	<u>47 days</u>
Total to Date	47 days

	Substantial Completion	Final Completion
Original Contract Date	12/1/2008	3/30/2009
Revised Contract Date - Previous Change Order	N/A	N/A
Revised Contract Date - This Change Order	N/A	5/16/2009

APPROVALS:

ENGINEER:
Dannenbaum Engineering Company - McAllen, LLC

OWNER:
Hidalgo Co. Drainage Dist. No. 1

Richard D. Seitz, P.E. Date 6/17/09
Resident Project Representative

JD Salinas Date
Chairman of the Board

ACCEPTED:

CONTRACTOR:
Williams Brothers Construction Co., Inc.

Randy T. Rogers Date 6-24-09
Vice-President

**HIDALGO COUNTY
JUL 02 2009
DRAINAGE DISTRICT #1**

HIDALGO COUNTY DRAINAGE DISTRICT NO. 1
LEVEE IMPROVEMENTS PROJECT

CHANGE ORDER NO. 13

ATTACHMENT B

Date: July 2, 2009

Contractor: WILLIAMS BROTHERS
CONSTRUCTION CO., INC.
3800 Milam
Houston, Texas 77006

Owner: Hidalgo County Drainage District No. 1
902 N. Doolittle Road
Edinburg, Texas 78541

Reference: LEVEE IMPROVEMENTS
PROJECT
DHS SEGMENT 0-10 (2.34 MI)

Contract No. 08-014-07-08
Dannenbaum No. 4410-05

ENGINEER'S EXPLANATION

DESCRIPTION OF CHANGE

Revised Final Completion date from March 30, 2009 to May 16, 2009.

JUSTIFICATION FOR CHANGE

Additional time required for processing of final project closeout documentation.

ENGINEER'S JUSTIFICATION OF COST

N/A

HIDALGO COUNTY

JUL 02 2009

DRAINAGE DISTRICT #1

PF225 Change Request (O-4 thru O-10)

Change Request Number: 109
USBP Sector: RGV

Change Request Date: 6 May 2009
Project/Map ID: O-10

SBI Project Manager: Scott Recinos
Change Requested By

USBP Sector TI Coordinator: SBPA Rene Zamora

Name: Scott Recinos

Telephone Number: 202-344-3215

E-mail Address: Scott.Recinos@cbp.dhs.gov

Fax Number: 202-344-1250

Description of Requested Change:

Levee/Wall DHS Segment O-10 – Change Order No. 13

Revise final completion date from March 30 to May 16, 2009.

Justification for Change:

Final close out of project delayed due to issues beyond the control of the contractor.

Cost Adjustment:

ROM \$0

Schedule Adjustment:

47 days

Notes:

1. SBI TI has reviewed the documentation provided by Hidalgo and believes approving this change request is in CBP's best interest and the best interest of the project.

Approval Signature:



Loren Flossman, Program Manager
Facilities Management & Engineering

18 MAY 09
Date

HIDALGO COUNTY

JUL 02 2009

DRAINAGE DISTRICT #1